



NETWORK CAMERA

**Model: IKS-WP816R**

---

**User's Manual**



For information on our latest products and peripheral devices, refer to the following web site:

[www.toshibasecurity.com](http://www.toshibasecurity.com)

If the URL changes, refer to [www.toshiba.com](http://www.toshiba.com)



18x 2MP Outdoor IP PTZ Camera (IKS-WP816R)

User Manual

Manual Edition – NOVEMBER 2014

©2013, TOSHIBA

All Rights Reserved.

No part of this documentation may be reproduced in any means, electronic or mechanical, for any purpose, except as expressed in the Software License Agreement. Toshiba shall not be liable for technical or editorial errors or omissions contained herein. The information in this document is subject to change without notice.

The information in this publication is provided “as is” without warranty of any kind. The entire risk arising out of the use of this information remains with recipient. In no event shall TOSHIBA be liable for any direct, consequential, incidental, special, punitive, or other damages whatsoever (including without limitation, damages for loss of business profits, business interruption or loss of business information), even if TOSHIBA has been advised of the possibility of such damages and whether in an action or contract or tort, including negligence.

This documentation is copyrighted. All other rights are reserved to TOSHIBA. TOSHIBA, and Surveillix, are registered trademarks of TOSHIBA in the United States and elsewhere; Windows, and Windows XP Embedded are registered trademarks of Microsoft Corporation. All other brand and product names are trademarks or registered trademarks of the respective owners.

TOSHIBA

Irvine, CA • U.S.A.

---

## Important Safeguards

---

### 1. Read Instructions

Read all the safety and operating instructions before operating the product.

### 2. Retain Instructions

Retain the safety instructions and user's manual for future reference.

### 3. Warnings

Comply with all warnings on the product and in the user's manual.

### 4. Follow Instructions

Follow all operating and use instructions.

### 5. Cleaning

Disconnect this camera from the power supply before cleaning.

### 6. Attachments

Do not use attachments not recommended by the camera manufacturer as they may pose safety risks.

### 7. Accessories

Do not place this camera on an unstable cart, stand, tripod, bracket or table. The camera may fall, causing serious injury to a person, or serious damage to the product. Use only withstand, tripod, bracket, or table recommended by the manufacturer, or sold with the camera. Any mounting of the product should follow the manufacturer's instructions, and should use amounting accessory recommended by the manufacturer.

### 8. Ventilation

This camera should never be placed near or over a radiator or heat register. If this product is placed in a built-in installation, verify that there is proper ventilation so that the camera temperature operates within the recommended temperature range.

### 9. Power Sources

This camera should be operated only from the type of power source indicated on the information label. If you are not sure of the type of power supply at your location, consult your product dealer.

### 10. Power-Cord Protection

Power cords should be routed so that they are not likely to be walked on or pinched by items placed upon or against them. Pay particular attention to cords at plugs, screws and the point where they exit the product.

### 11. Installation

Install this camera on a secure part of the ceiling or wall. If installed on an unsecured location the camera could fall causing injury and damage.

### 12. Lightning

For additional protection on this camera during a lightning storm, or when it is left unattended and unused for long periods of time, unplug it from the wall outlet and disconnect the power supply and cable system. This will prevent damage to the camera due to lightning and power line surges. If lightning occurs, do not touch the unit or any connected cables in order to avoid electric shock.

### **13. Overloading**

Do not overload the power supply or extension cords as this can result in a risk of fire or electric shock.

### **14. Object and Liquid Entry**

Never push objects of any kind into this camera through openings as they may touch dangerous electrical points or short-out parts that could result in a fire or electrical shock. Never intentionally spill liquid of any kind on the camera.

### **15. Servicing**

Do not attempt to service this camera yourself as opening or removing covers may expose you to dangerous electrical or other hazards. Refer all servicing to qualified service personnel.

### **16. Damage Requiring Service**

Disconnect this camera from the power supply and refer servicing to qualified service personnel under the following conditions.

- a. When the power-supply cord or plug is damaged.
- b. If liquid has been spilled, or objects have fallen into the camera.
- c. If the camera has been submerged in water.
- d. If the camera does not operate normally by following the operating instructions in the user's manual. Adjust only those controls that are covered by the user's manual as an improper adjustment of other controls may result in damage and will often require extensive work by a qualified technician to restore the camera to its normal operation.
- e. If the camera has been dropped or the cabinet has been damaged.
- f. When the camera exhibiting a distinct change in performance which indicates a need for service.
- g. Other trouble.

### **17. Replacement Parts**

When replacing parts, be sure the service technician uses parts specified by the manufacturer or have the same characteristics as the original part. Unauthorized substitutions may result in fire, electric shock or other hazards.

### **18. Safety Check**

Upon completion of any service or repairs to this camera, ask the service technician to perform safety checks to determine that the camera is in proper operating condition.

---

## Precautions

---

### Operating

- Before using, make sure power supply and other cables are properly connected.
- While operating, if any abnormal condition or malfunction is observed, stop using the camera immediately and then contact your local dealer.

### Handling

- Do not disassemble or tamper with parts inside the camera.
- Do not drop or subject the camera to shock and vibration as this can damage camera.
- Do not block the cooling holes on the bracket. This camera has a cooling fan inside the housing. Blocking the cooling holes will cause heat to build up and cause malfunction.
- Care must be taken when you clean the clear dome cover. Scratches and dust will ruin the image quality of your camera. Do not use strong or abrasive detergents when cleaning the camera body. Use a dry cloth to clean the camera when it is dirty. In case the dirt is hard to remove, use a mild detergent and wipe the camera gently.

### Installation and Storage

- Install electricity wiring carefully. Please note that input electricity to the unit is at tolerance of DC 12V/AC 24V  $\pm$  10%. The camera is capable of surge protection; ensure AC power model unit is grounded appropriately against damage by heavy current or electric shock.
- Do not install the camera in areas of extreme temperatures in excess of the allowable range. (-40°C ~50°C / -40°F ~ 122°F)
- Avoid installing in humid or dusty places. The relative humidity must be below 90%.
- Avoid installing in places where radiation is present.
- Avoid installing in places where there are strong magnetic fields and electric signals.
- Avoid installing in places where the camera would be subject to strong vibrations.
- Whether the camera is in use or not, never aim it at the sun or other extremely bright objects. Otherwise the camera may be smeared and damaged.

### Should you notice any trouble

- If any trouble occurs while you are using the camera, turn off the power and contact your dealer. If you continue to use the camera when there is something wrong with it, the trouble may get worse and an unpredictable problem may occur.

## **Disclaimer**

- We disclaim any responsibility and shall be held harmless for any damages or losses incurred by the user in any of the following cases:
  1. Fire, earthquake or any other act of God; acts by third parties; misuse by the user, whether intentional or accidental; use under extreme operating conditions.
  2. Malfunction or non-function resulting in indirect, additional or consequential damages, including but not limited to loss of expected income and suspension of business activities.
  3. Incorrect use not in compliance with instructions in this user's manual.
  4. Malfunctions resulting from misconnection to other equipment.
  5. Repairs or modifications made by the user or caused to be made by the user and carried out by an unauthorized third party.
- Notwithstanding the foregoing, Toshiba's liabilities shall not, in any circumstances, exceed the purchase price of the product.

## **Copyright and Right of Portrait**

- There may be a conflict with the Copyright Law and other laws when a customer uses, displays, distributes, or exhibits an image picked up by the camera without permission from the copyright holder. Please also note that transfer of an image or file covered by copyright is restricted to use within the scope permitted by the Copyright Law.

## **Protection of Personal Information**

- Images taken by the camera that reveal the likeness of an individual person may be considered personal information. To disclose, exhibit or transmit those images over the internet or otherwise, consent of the person may be required.

## **Usage Limitation**

- The product is not designed for any "critical applications." "Critical applications" means life support systems, exhaust or smoke extraction applications, medical applications, commercial aviation, mass transit applications, military applications, homeland security applications, nuclear facilities or systems or any other applications where product failure could lead to injury to persons or loss of life or catastrophic property damage.
- Accordingly, Toshiba disclaims any and all liability arising out of the use of the product in any critical applications.

---

## **Regulation**

---

### **FCC (USA) Information**

This device complies with Part 15 of the FCC Rules. Operation is subject to the following two conditions:

- (1) This device may not cause harmful interference, and
- (2) This device must accept any interference received, including interference that may cause undesired operation.

NOTE: This equipment has been tested and found to comply with the limits for a Class A digital device, pursuant to Part 15 of the FCC Rules.

These limits are designed to provide reasonable protection against harmful interference when the equipment is operated in a commercial environment. This equipment generates, uses, and can radiate radio frequency energy and, if not installed and used in accordance with the instruction manual, may cause harmful interference to radio communications. Operation of this equipment in a residential area is likely to cause harmful interference in which case the user will be required to correct the interference at his own expense.

CAUTION: Your authority to operate this FCC verified equipment could be voided if you make changes or modifications not expressly approved by the party.

Industry Canada Information

CAN ICES-3 A / NMB-3 A



This symbol on the product or on its packaging indicates that this product shall not be treated as household waste in accordance with Directive 2002/96/EC. Instead it shall be handed over to the applicable collection point for the recycling of electrical and electronic equipment. By proper waste handling of this product you ensure that it has no negative consequences for the environment and human health, which could otherwise be caused if this product is thrown into the garbage bin. The recycling of materials will help to conserve natural resources.

For more details information about recycling of this product, please contact your local city office, your household waste disposal service or the shop where you purchased the product.



Compliance is evidenced by written declaration from our suppliers, assuring that any potential trace contamination levels of restricted substances are below the maximum level set by EU Directive 2002/95/EC, or are exempted due to their application

---

## Warning

---

TO REDUCE THE RISK OF FIRE OR ELECTRIC SHOCK, DO NOT EXPOSE THIS APPLIANCE TO RAIN OR MOISTURE.

DANGEROUS HIGH VOLTAGES ARE PRESENT INSIDE THE ENCLOSURE.  
DO NOT OPEN THE CABINET.

THIS INSTALLATION SHOULD BE MADE BY A QUALIFIED SERVICE PERSON  
AND SHOULD CONFORM TO ALL LOCAL CODES.  
REFER SERVICING TO QUALIFIED PERSONNEL ONLY.

---

## Caution

---

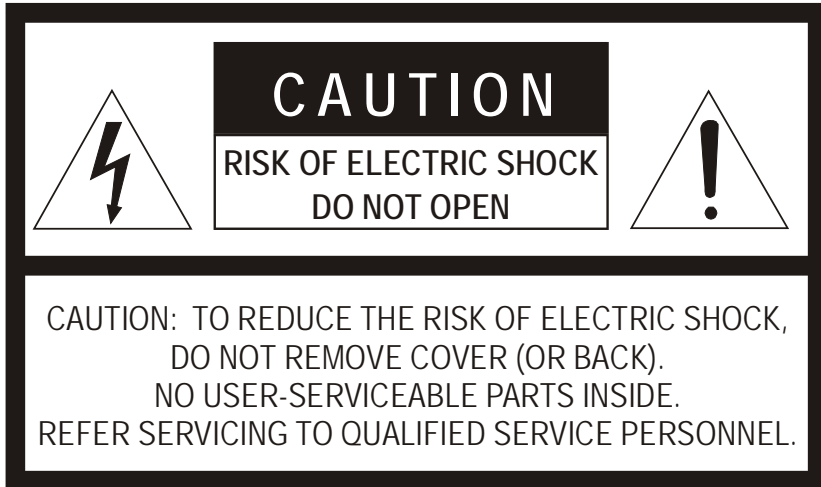

# TABLE OF CONTENTS

<b>Introduction .....</b>	<b>14</b>
Overview .....	14
Product Features .....	14
<b>Getting Started .....</b>	<b>15</b>
Camera Contents .....	15
Dome Setup and Cable Connection .....	16
Preparations for Dome Setup .....	16
Dome Camera Setup .....	19
Switch Definition .....	19
Dome Cable Definition and Requirements .....	20
Cable Requirements .....	20
Power Connection .....	21
Grounding Recommendation .....	21
Ethernet Cable Connection .....	21
12-Pin Alarm Input/Output Connection .....	22
Audio Input/Output Connection .....	22
<b>Dome Installation .....</b>	<b>23</b>
Overview .....	23
Dome Dimensions .....	23
Optional Accessories .....	24
Dome Camera Accessories .....	<b>Error! Bookmark not defined.</b>
Mounting Accessories .....	24
Ceiling Mounting with Pole .....	24
Wall Mounting with Wall Mount Bracket .....	26
Wall Mounting with Corner Mount .....	28
Pole Mounting .....	29
<b>Locate Camera .....</b>	<b>30</b>
Surveillix Device Search .....	30
Installation .....	30
Starting Device Search .....	30
Device Addressing .....	31
Finding Network Devices .....	31
<b>Setup &amp; Configuration .....</b>	<b>32</b>

Connecting to the Camera .....	32
Administrator/User Privileges .....	32
Connecting a Stream .....	33
Connecting Over the Internet .....	34
Viewer Software .....	35
Viewer Tabs .....	35
Home .....	36
System .....	38
System.....	38
Security.....	40
Admin Password .....	40
Add User .....	41
Delete User .....	41
Edit User .....	41
Network .....	42
Get IP address automatically (DHCP) .....	42
Use Fixed IP Address .....	42
QoS (Quality of Service) .....	44
SNMP .....	44
UPnP (Universal Plug and Play) .....	45
DDNS .....	46
Mail .....	47
FTP .....	48
HTTP .....	49
Application .....	50
Alarm Pin Selection .....	51
Alarm Pin Status Settings.....	52
Motion Detection .....	54
Storage Management.....	57
Recording .....	59
Activating Micro SD/SDHC Card Recording.....	59
Snapshot .....	60
Information .....	61
System Log .....	61
View User Information .....	62
View User Privilege.....	62
Parameter List .....	63
Software Upgrade .....	64
Upgrading the Camera Viewer Software .....	64

Maintenance.....	65
Video and Audio Streaming Settings.....	66
Video Format.....	66
Video Resolution.....	67
Text Overlay Settings .....	67
Video Rotate Type .....	68
GOP Settings.....	68
H.264 Profile .....	68
Video Compression.....	69
Video OCX Protocol .....	70
Multicast Mode.....	70
Frame Rate Control.....	71
Audio .....	72
Transmission Mode .....	72
Server Gain Settings.....	72
Bit Rate .....	73
PTZ Settings .....	74
Preset .....	74
Preset Setting.....	74
Preset Go .....	75
Pattern .....	75
Pattern Setting .....	75
Pattern Run .....	76
Auto Scan .....	76
Auto Scan Setting .....	77
Auto Scan Run .....	77
Tour .....	78
Tour Set.....	79
Tour Run .....	79
Home .....	80
Home Settings.....	80
Tilt Range .....	80
Privacy Mask Settings .....	82
Mask Setting .....	83
Mask Clearing .....	83
Camera — Exposure .....	84
Camera — White Balance .....	85

Camera — Misc1 .....	87
Camera — Misc2 .....	89
Camera — Default .....	90
Logout .....	90
<b>Specifications .....</b>	<b>91</b>
Camera Specifications .....	91
PTZ Specifications .....	92
IP Specifications .....	92

# INTRODUCTION

## OVERVIEW

---

The IKS-WP816R IP camera can transmit video in H.264 and MJPEG, up to 2MP (1080p) high definition video. The IKS-WP816R is capable of quad and dual streaming both codecs at various resolutions. The camera's IR cut filter and wide dynamic range imaging make it perfect for installations with difficult lighting conditions. The IKS-WP816R has an IP66 outdoor rating and integrated heater making the IKS-WP816R ideal for rugged outdoor installations with temperature as low as -40°F (-40°C)

## Product Features





- 18x optical zoom
- 2 megapixel resolution
- Simultaneous dual streams: H.264 and MJPEG
- Full HD real-time resolution
- Two-way audio support
- Removable IR cut filter
- Motion detection
- Wide Dynamic Range (WDR)
- Digital noise reduction

# GETTING STARTED

## CAMERA CONTENTS

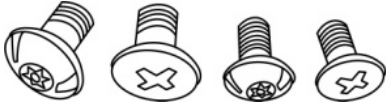
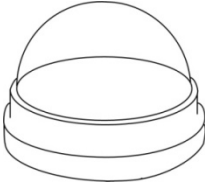
---

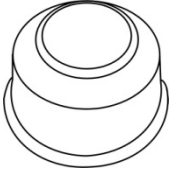
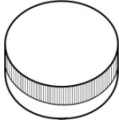
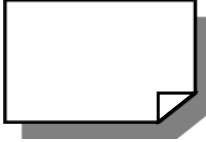
Before proceeding, please check that the box contains the items listed here. If any item is missing or has defects, do not install or operate the product and contact your dealer for assistance.

 <p><b>Dome Body</b></p>	 <p><b>1 M3 Standard Screw</b> <b>1 M3 Security Screw</b> <b>1 M5 Standard Screw</b> <b>1 M5 Security Screw</b></p>	
 <p><b>Optical Cover</b></p>	 <p><b>Security Torx Tool</b></p>	 <p><b>Waterproof Gasket</b></p>
 <p><b>Lubricant</b></p>	 <p><b>Quick Start Guide</b></p>	 <p><b>CD</b></p>

# DOME SETUP AND CABLE CONNECTION

---

Before installing or connecting the dome camera, please refer to this section and complete preparations for dome setup and all switch settings.

## Preparations for Dome Setup

The following installation procedure is for the outdoor dome equipped with the sunshield housing. Please follow the steps below to complete dome housing installation.

1. Unpack the dome package and take out the dome body.



2. Rotate the top holder and take it off from the dome body.



3. Remove the protective cover and PE sheet.

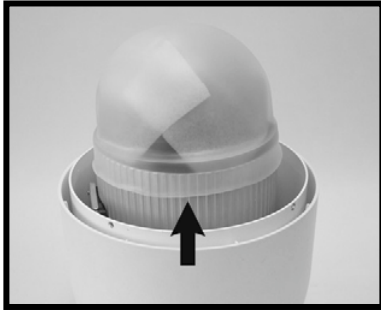

4. Apply some lubricant on the cover's waterproof gasket. This helps make the installation process smoother.

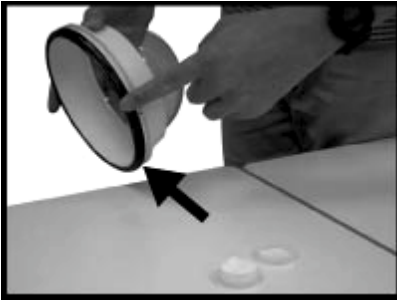

5. Attach the dome cover to the camera body.
6. Note that the tiny protrusion on the cover must align with one of the four holes on the camera body.



7. Using both hands, gently press the dome cover.

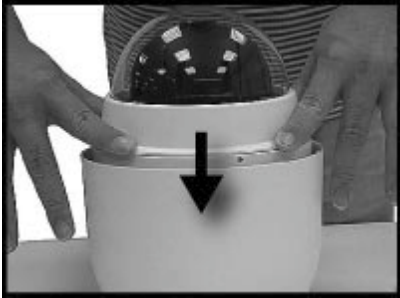

DO NOT press the dome itself as this may cause damage to the dome or camera.



8. Screw the dome cover and body together.



# Dome Camera Setup

## Switch Definition

Please refer to the following figure for connection and switch locations and definitions.

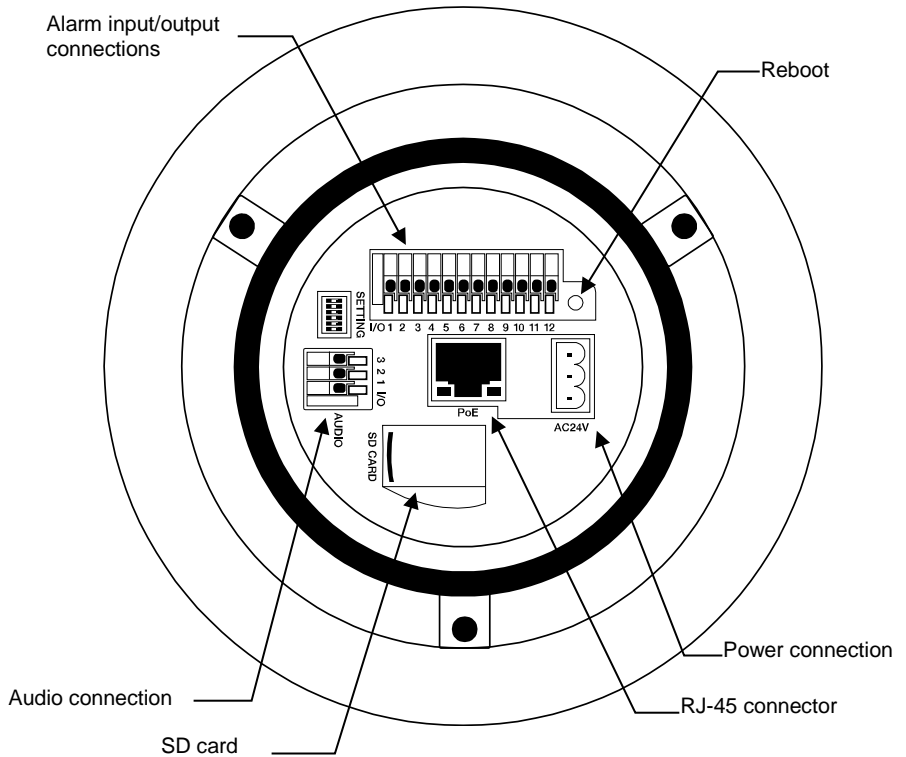

**Note** Do not change the settings on the camera's settings switches. Leave the switches at the factory default settings.

# Dome Cable Definition and Requirements

For operation, the IP dome camera requires a network cable to carry the video signals to the remote viewing site and a power cable to power the dome.

## ***Cable Requirements***

For operation, the IKS-WP816R IP camera requires 24V AC power to the dome.

### **Power Wire Length Specifications**

<b>Wire Gauge</b>	<b>Maximum Distance</b>	<b>Wire Gauge</b>	<b>Maximum Distance</b>
22	27 feet	14	175 feet
20	44 feet	12	279 feet
18	69 feet	10	444 feet
16	110 feet		

**Note** Ensure that the power supply corresponds with the dome's power requirement or the camera may be damaged. Contact a qualified maintenance engineer with any problems.

### **Network Cable Length Specifications**

<b>Cable Type</b>	<b>Maximum Distance</b>	<b>Wire Gauge</b>	<b>Maximum Distance</b>
CAT5	300 feet	CAT6	300 feet
CAT5e	300 feet	CAT6a	300 feet

**Note** An Ethernet crossover cable can be used to connect the camera directly to a PC during configuration.

## ***Power Connection***

1. Connect **POSITIVE** 24 volt AC power to pin **1**.
2. Connect ground wire to pin **2**.
3. Connect **NEGATIVE** 24 volt AC power to pin **3**.

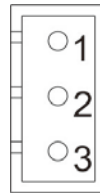

**Note** The 'notches' on the left side of the graphic above correspond to notches in the green plastic of the power connector.

**Note** Be careful not to pull the cables improperly during installation. Toshiba suggests that you fasten the cables after installation is complete.

## ***Grounding Recommendation***

The GND (ground) wire must be directly connected to the middle pin of the AC24V power connector. Failure to connect the ground can cause damage and failure of the camera and may void the warranty.

## ***Ethernet Cable Connection***

Connect one end of the CAT 5 Ethernet cable to the RJ-45 connector of the camera and the other end of the cable to the network switch or recorder.

**Note** In some cases, you may need to use an Ethernet crossover cable when connecting the camera directly to the recorder.

Check the status of the link indicator and activity indicator LEDs. If the LEDs are unlit, check the LAN connection.



The Green link light indicates a good network connection.

The Orange activity light flashes to indicate network activity.

## 12-Pin Alarm Input/Output Connection

Using the 12-pin connector, installers can connect 4 digital alarm inputs and 2 digital alarm outputs. The alarm pins are serviceable for connecting alarm input and output devices such as sensors, sirens, or flashing lights to the surveillance system. For the definition of each pin, refer to the list below.

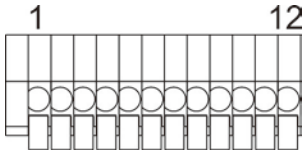

Pin	Definition
1	Alarm OUT NO 1
2	Alarm OUT NC 1
3	Alarm OUT COM 1
4	GROUND
5	Alarm OUT NO 2
6	Alarm OUT NC 2
7	Alarm OUT COM 2
8	GROUND
9	Alarm IN 4
10	Alarm IN 3
11	Alarm IN 2
12	Alarm IN 1

## Audio Input/Output Connection

1. Line OUT
2. GROUND
3. Line IN

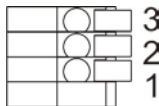

# DOME INSTALLATION

## OVERVIEW

---

Depending on your installation environment, the dome can be installed on the ceiling, on a wall, or a pole. The following section illustrates installation methods and procedures for installing the dome and mounting accessories.

## DOME DIMENSIONS

---

The dome dimensions are  $\text{Ø}172 \times 228.71\text{mm}$  (6.77 x 9.0 inches) and  $\text{Ø}191.97 \times 282.11\text{mm}$  (7.5 x 11.1 inches) with the sunshield.

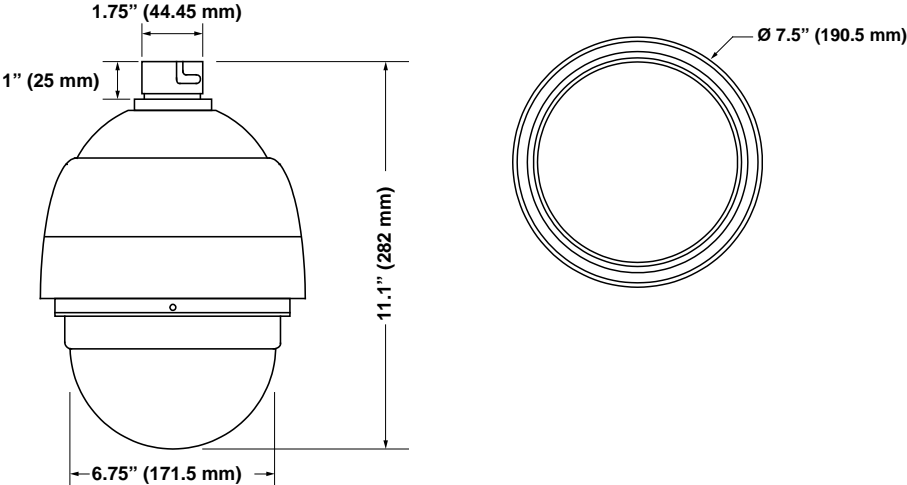

# OPTIONAL ACCESSORIES

---

## Mounting Accessories

### **Wall Mount Bracket (w/ Anti Drop)**

Part Number: JK-510W

### **Long Wall Mount Bracket (w/ Anti Drop)**

Part Number: JK-510WL

### **50 cm Pole**

Part Number: JK-510P50

### **25 cm Pole**

Part Number: JK-510P25

### **Corner Mounting Plate**

Part Number: JK-510C

### **Large Pole Mount**

Part Number: JK-510PML

### **1 ¼” Threaded Adapter**

Part Number: JK-510PA25

### **1 ½” Threaded Adapter**

Part Number: JK-510PA50

## Ceiling Mounting with Pole

The pole is available in two lengths: 25 cm and 30 cm.

### **Items Needed:**

- Dome Camera
- Ceiling Pole Accessory
- Waterproof Gasket (supplied)

- Screws and Anchors appropriate for the mounting surface (not supplied)

### **Tools Needed:**

- Drill

- Screwdriver

### Installation Steps:

**Note** Ensure that the ceiling can support the weight of the dome camera and the ceiling pole.

1. Cut a cable access hole in the ceiling.
2. Attach the ceiling pole to the ceiling with the appropriate screws and screw anchors (not provided).
3. Attach the waterproof gasket to the Ceiling Pole.
4. Thread the cables through the ceiling pole and the top holder

**Note** After threading the cables through the tube, block the cable entry hole with the supplied sponges to prevent insects from entering the tube.

5. Attach the top holder to the ceiling pole with the supplied screws and washers and adjust the gasket to the junction of the ceiling pole and the top holder.
6. Connect the cables to the dome camera.
7. Attach the dome to the top holder and secure them with the supplied screw.

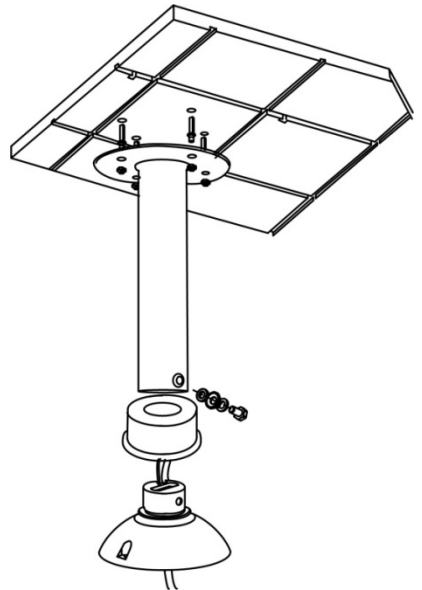

# Wall Mounting with Wall Mount Bracket

## Items Needed:

- Dome Camera
- Wall Mount Bracket or Long Wall Mount Bracket
- Waterproof Gasket (supplied)
- Screws and Anchors appropriate for the mounting surface (not supplied)

## Tools Needed:

- Drill
- Screwdriver

## Installation:

1. Cut a cable access hole on the wall. Cables can also be threaded through the cable entry knockout on the tube if desired.
2. Thread the cables through the wall mount bracket.



3. Block the cable entry hole with the supplied sponge.

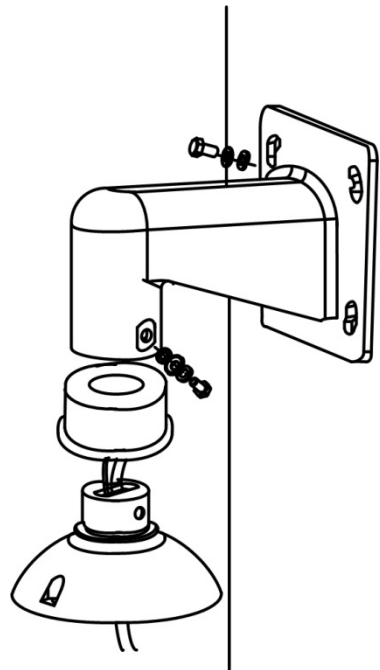
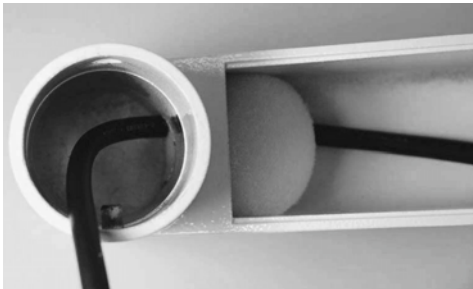

4. Attach the wall mount bracket to the wall with the appropriate screws and screw anchors (not provided).
5. Attach the waterproof gasket to the wall mount bracket.
6. Thread the cables through the top holder and attach the dome to the wall mount bracket with the supplied screws and washers.
7. Connect the cables to the dome camera.
8. Attach the dome to the top holder and secure them with the supplied screw.

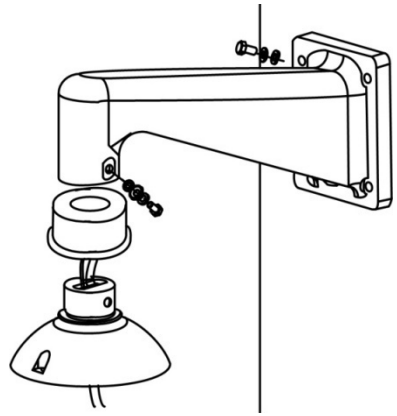

# Wall Mounting with Corner Mount

The corner mount must be used in conjunction with the wall mount bracket.

## Items Needed:

- Dome Camera
- Wall Mount Bracket Accessory
- Corner Mounting Plate
- Waterproof Gasket (supplied)
- Screws and Anchors appropriate for the mounting surface (not supplied)

## Tools Needed:

- Drill
- Screwdriver

## Installation:

1. Cut a cable access hole on the wall. Cables can also be threaded through the cable entry knockout on the bracket if desired.
2. Secure the corner mount plate on the corner wall with the appropriate screws and screw anchors.
3. Attach the wall mount bracket to the corner mount plate with the supplied screws and washers.
4. Thread the cables through wall mount bracket and the top holder.
5. Block the cable entry hole with the supplied sponge.
6. Attach the waterproof gasket to the wall mount bracket.
7. Attach the top holder to the wall mount bracket with the supplied screws and washers and adjust the gasket to the junction of the wall mount bracket and the top holder.
8. Connect the cables to the dome camera.
9. Attach the dome to the top holder and secure them with the supplied screw.

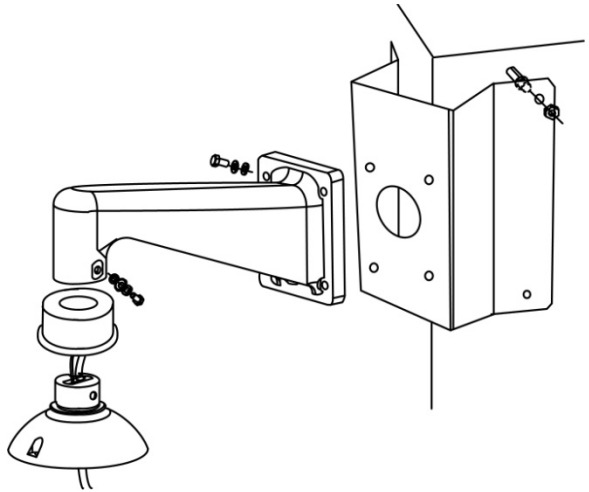

# Pole Mounting

The dome can be mounted on a pole with the small or large direct mounting accessory and a wall mount bracket.

## Items Needed:

- Dome Camera
- Wall Mount Bracket Accessory
- Small/Large Pole Mount Accessory
- Stainless Steel Straps
- Waterproof Gasket (supplied)

## Tools Needed:

- Stainless Steel Strap Cutter
- Screwdriver

## Installation Steps:

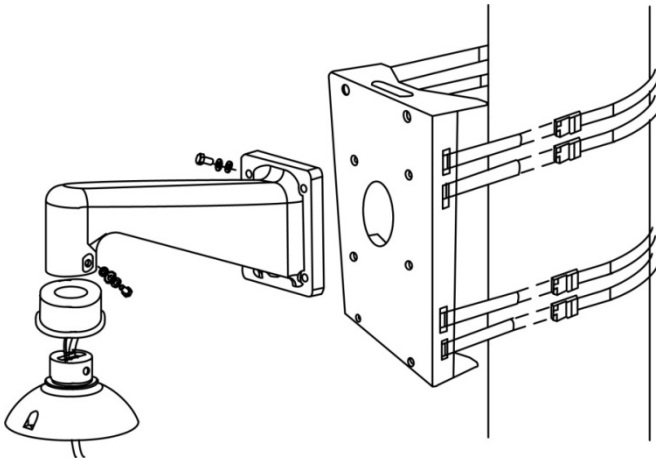

1. Fasten the small/large pole mount to the pole with stainless steel straps.
2. Attach the wall mount bracket to the pole mount with the supplied screws and washers.
3. Attach the waterproof gasket to the wall mount bracket.
4. Thread the cables through the wall mount and the top holder.
5. Block the cable entry hole with the supplied sponge.
6. Attach the top holder to the wall mount with the supplied screws and washers and adjust the gasket to the junction of the wall mount and the top holder.
7. Connect the cables to the dome camera.
8. Attach the dome to the top holder and secure them with the supplied screw.

# LOCATE CAMERA

## SURVEILLIX DEVICE SEARCH

---

Use the included Device search software to easily find your network cameras for initial setup. The Surveillix Device search software is included on the CD with all Surveillix IP devices.

### Installation

You can run Device search on any personal computer (PC) or laptop using the software CD included with your Surveillix IP camera or by downloading the program from [toshibasecurity.com](http://toshibasecurity.com).

**Note** Device search will only work on PCs or laptops that use a Windows operating system. It is compatible with Windows XP, Vista, 7, and 8.

### Starting Device search

After installing the program on your PC or laptop, open the program to begin configuring your cameras.

To access Device search on a Surveillix recorder, you must operate the recorder in Windows Mode.

1. In the Live Screen, click **Exit**.
2. Click **Restart in Windows Mode**.
3. Click **OK**.
4. Double-click **Device search**.

# Device Addressing

The functions on the Device Addressing tab allow you to find, configure, and view network cameras.

## *Finding Network Devices*

1. Click **Find Devices** on the **Device Addressing** tab.
2. To narrow your search by **Camera Model**, **Project**, or **Camera Name**, select your desired criteria from the appropriate lists.

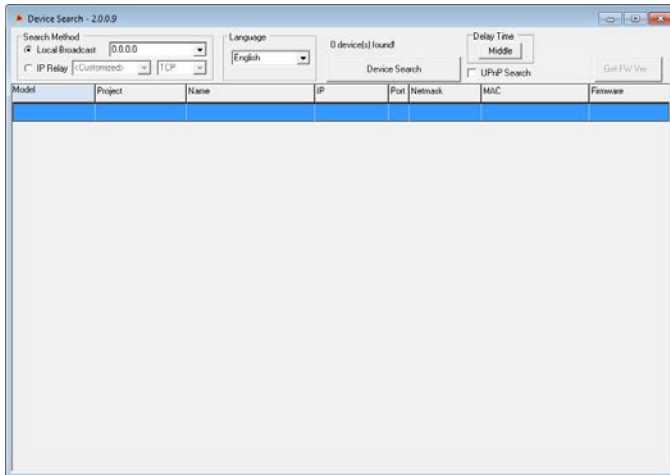

# SETUP & CONFIGURATION

## CONNECTING TO THE CAMERA

---

1. Locate the camera on the **Device search** list.
2. Double-click the camera to open the Viewer software in your web browser.
3. Log in to the camera with the appropriate **User Name** and **Password**.

**Note** The default User name is **Admin** and the default Password is **1234**. The username and password are case sensitive. Toshiba recommends you change the Admin password for security reasons.

## Administrator/User Privileges

The Administrator account has the authority to configure the IP camera and authorize users' access to the camera. The User accounts have access to the camera with limited authority.

# Connecting a Stream

Surveillix IP cameras are optimized for use with Toshiba recorders, but you can also connect to your Surveillix IP cameras using third party software like VLC media player (<http://www.videolan.org>).

To connect the camera you may need to provide the stream URL. All Surveillix IP cameras are capable of delivering two RTSP streams, as well as streaming MJPEG over HTTP. The stream URLs are listed below.

rtsp://<ip address>/mjpeg

rtsp://<ip address>/mpeg4

rtsp://<ipaddress>/h264

http://<ipaddress>:8008

The MJPEG over HTTP stream is identified by a port number. The default port is 8008; this port can be configured in the cameras **Network** page:

The screenshot shows the 'Network' configuration page of a camera. The page has a navigation bar with 'Home', 'System', 'Streaming', 'Camera', and 'Logout'. A sidebar on the left lists various system settings. The main content area is titled 'Network' and contains the following sections:

- General**
  - Get IP address automatically
  - Use fixed IP address
    - IP address: 10.4.5.86
    - Subnet mask: 255.0.0.0
    - Default gateway: 10.0.0.50
    - Primary DNS: 10.0.0.19
    - Secondary DNS: 0.0.0.0
  - Use PPPoE
    - User name: [text box]
    - Password: [text box]
    - [Save button]
- Advanced**
  - Web Server port: 80
  - RTSP port: 554
  - MJPEG over HTTP port: 8008 (highlighted with a red arrow)
  - [Save button]
- UPnP Setting**
  - Enable UPnP
  - Enable UPnP port forwarding
  - Friendly name: CM-730
  - [Save button]

## Connecting Over the Internet

There are some challenges with connecting to Surveillix IP cameras over WAN (internet) connections because the camera streams video over RTSP. RTSP is an excellent protocol for media and is now used on many IP cameras (including Surveillix) as the default streaming option.

However, RTSP is not suitable for transmission between two locations that are behind different routers. In this case, the client (for example, the Surveillix server software) connects to the camera, then requests a stream. The camera uses that connection to return a stream, but since the connection originated on the client side and has now switched to the camera (remote) side, the router does not have any way to determine where the traffic should be routed, so no video appears at the recorder.

There are three solutions to this:

1. Connect modems on both sides directly to the recorder and camera. If there is no router, no network address translation is needed.
2. Use routers with VPN support and set up a small VPN. Once this is done, the traffic will be treated as though it were all on the local network.
3. **(Best solution)** – Use routers with **connection tracking**. This is quite easy; VOIP also uses RTSP and faces the same challenges. If a router is marketed as having “VOIP Support”, it will have the necessary connection tracking capability to allow any type of RTSP communication (not just VOIP).

With proper planning and the correct equipment, RTSP cameras CAN stream over the WAN to a recording device for minimal additional cost and labor.

Please contact Toshiba support if you require any additional information on these topics.

# VIEWER SOFTWARE

---

To access the setup menu, you need to install the viewer software on your PC or DVR. The viewer software will install automatically the first time you connect to the camera. If your internet browser doesn't install the viewer software, check the security settings or ActiveX controls and plug-in settings. If your internet browser asks for permission to install the ActiveX control, you must allow the ActiveX control to continue the installation.

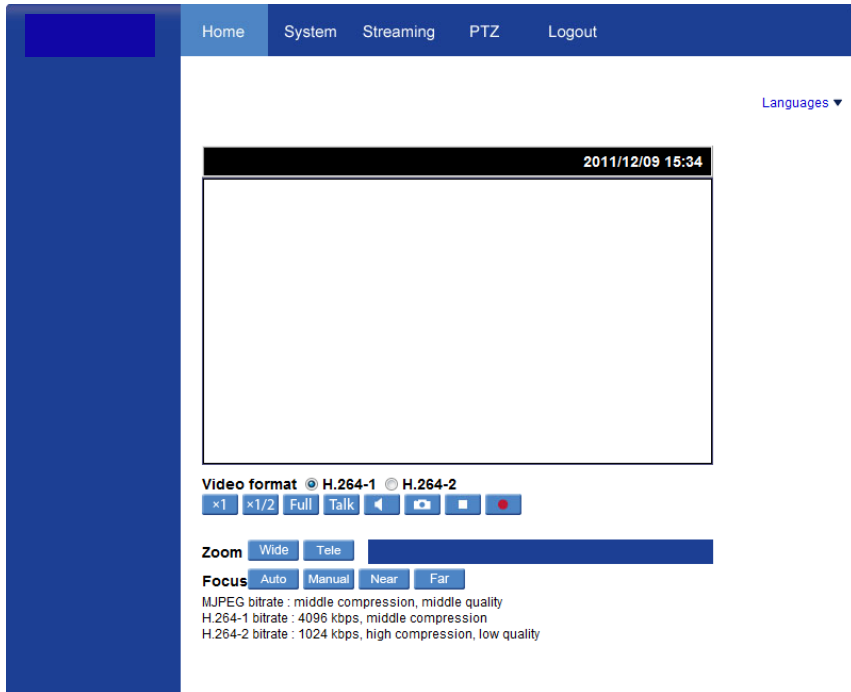

## Viewer Tabs

**Home** – Monitor live video.

**System** – Set the host name, system time, root password, and network related settings. (Admin access only)

**Streaming** – Modify the video resolution and select the audio compression type.

**PTZ** – Adjust the camera parameters including Exposure, White Balance, Backlight Compensation and program functions including Presets, Pattern, Auto Scan, and Tour.

**Logout** – Change user.

# Home

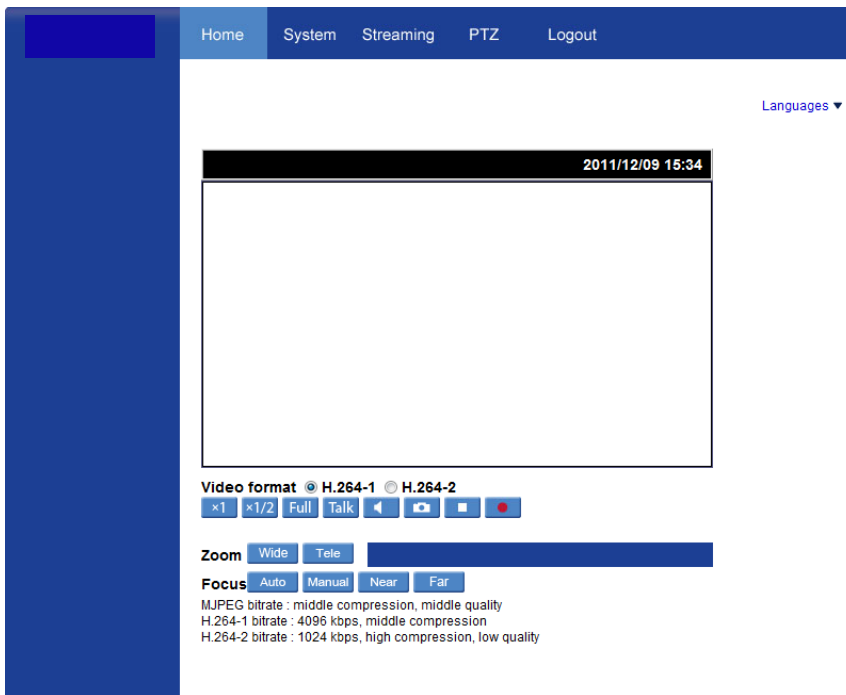

## Screen Size Adjustment

Image display size can be adjusted to x1/2 and full screen via the related buttons. To switch between the normal view mode and full screen view mode, users can also move the cursor to the live video pane and right-click to display the screen options. Click Normal View or Fullscreen to set the image display mode.

## Talk

The Talk function allows the local site to talk to the remote site (camera location). This function is only available if the local site has a connected microphone, the remote site has connected speakers, and the local user has been granted access. Please refer to the **Security: Add user > Talk/Listen** section for further details. This function is only available to users who have been granted this privilege by the Administrator.

## Listen

The Speaker function allows the local site to listen to audio from the remote site (camera location). This function is only available if the local site has connected speakers, the remote site has a connected microphone, and the local user has been granted access. Please refer to the **Security: Add user > Talk/Listen** section for further details. This

function is only available to users who have been granted this privilege by the Administrator.

### **Snapshot**

Click the Snapshot button, and a JPEG snapshots will automatically be saved in the designated location on the local workstation. The default place of saving snapshots is: C:\. This location can be changed in File Location under the System menu.

**Note** If you are using Windows Vista or 7, you will need to change the snapshot location. Windows UAC does not allow internet programs to write directly to C:\ for security reasons.

### **Record**

Click the Record button to start recording live video; press the record button again to stop recording live video, automatically saving an AVI video clip to the designated location on the local workstation. The default place of saving video clips is: C:\. This location can be changed in File Location under the System menu.

**Note** If you are using Windows Vista or 7, you will need to change the video clip location. Windows UAC does not allow internet programs to write directly to C:\ for security reasons.

### **Pan/Tilt Control**

To implement pan/tilt control, move the cursor to the live video pane and drag the pointer  in the desired direction.

### **Zoom Adjustment**



Click on the **wide/tele** buttons to control zoom in/out. Or move the cursor to the zoom adjustment bar and click the desired position to change the room ratio. Or you can zoom in/out by first moving the cursor to the live video pane and rotating the mouse wheel.

### **Focus Adjustment**



#### **Auto Focus (Continuous AF):**

Click **Auto** to enable auto focus mode. In this mode, the camera will automatically and continuously adjust focus regardless of zoom changes or any view changes. The Focus status will also be displayed above the live video pane.

#### **Manual Focus:**

Click on **Manual** to adjust focus manually via the **Near** and **Far** buttons. The status will also be displayed above the live video pane.

# System

Note The **System** tab is only accessible by the Administrator.

## System

The screenshot shows a web interface with a navigation bar at the top containing 'Home', 'System', 'Streaming', 'PTZ', and 'Logout'. On the left is a sidebar menu with items: System, Security, Network, DDNS, Mail, FTP, HTTP, Application, Motion detection, Storage management, Recording, File location, View log file, View user information, View parameters, Factory default, Software version, and Software upgrade. The main content area is titled 'System' and contains the following configuration options:

- Host Name :** CM-816
- Time zone :** GMT+00:00 Gambia, Liberia, Morocco, England
- Enable daylight saving time**
  - time offset: 01:00:00
  - Start date: Jan 1st Sun Start time: 00:00:00
  - End date: Jan 1st Sun End time: 00:00:00
- Sync with computer time**
  - PC date: 2011/12/01 [yyyy/mm/dd]
  - PC time: 15:22:13 [hh:mm:ss]
- Manual**
  - Date: 2007/01/01 [yyyy/mm/dd]
  - Time: 00:00:00 [hh:mm:ss]
- Sync with NTP server**
  - NTP server: 0.0.0.0 [host name or IP address]
  - Update interval: Every hour
  -

### Host Name

The Host Name is used to identify the camera on your system. If camera based Motion Detection is enabled and is set to send alarm message by Mail/FTP, the host name entered here will display in the alarm message.

### Time Zone

Select the appropriate time zone from the dropdown.

### **Enable Daylight Savings Time**

Select to enable daylight savings time, then select the offset, start date and end date. In North America the typical offset is one hour (01:00:00); the start is the second Sunday in March at 2AM (02:00:00), and the end is the first Sunday in November at 2AM (02:00:00).

### **Sync with Computer Time**

Select to synchronize the camera date and time with the connected PC or DVR.

### **Manual**

Set video date and time manually.

### **Sync with NTP Server**

Network Time Protocol (NTP) is an alternate way to set your camera's clock by synchronizing with a NTP server. Specify the server you wish to synchronize in the **NTP Server** box. Then select an **Update Interval**. For more information about NTP, visit [www.ntp.org](http://www.ntp.org).

# Security

Home System Streaming PTZ Logout

System

Security

User

HTTPS

IP filter

IEEE 802.1X

Network

DDNS

Mail

FTP

HTTP

Application

Motion detection

Storage management

Recording

File location

View log file

View user information

View parameters

Factory default

Software version

### Security

#### Admin Password

Admin password

Confirm password

#### Add User

User name

User password

I/O access  Camera control

Talk  Listen

#### Manage User

User name

## Admin Password

To change the administrator password, type a new password in the Admin Password box and confirm below.

**Note** The maximum length of the password is 14 characters. The following characters are valid: A-Z, a-z, 0-9, !#\$%&'-.@^\_~.

## Add User

---

The user name and passwords are limited to 16 characters. There is a maximum of twenty user accounts

1. Type the new User name and Password
2. Select the appropriate check boxes to give the user Camera Control, Talk and Listen permissions.

**I/O Access** – Basic functions that enable users to view video when accessing to the camera.

**Camera Control** – Allows the User to change camera parameters on the Camera tab.

**Talk/Listen** – Talk and Listen functions allow the user at the local site (DVR) to communicate with, the administrator at the remote site.

3. Click **Add**.

## Delete User

---

1. Select the user name on the **User Name** list under **Manage User**.
2. Click **Delete** to remove the user.

## Edit User

---

1. Select the user name on the **User Name** list under **Manage User**.
2. Click **Edit** to edit the user password and permissions.
3. Type a new password or the existing password in the User password box

**Note** You must type a password in the User password box to make any changes to an account.

**Note** For security reasons, every time the user properties are opened the access check boxes are automatically cleared. Make sure you select any user access options each time you edit the user properties.

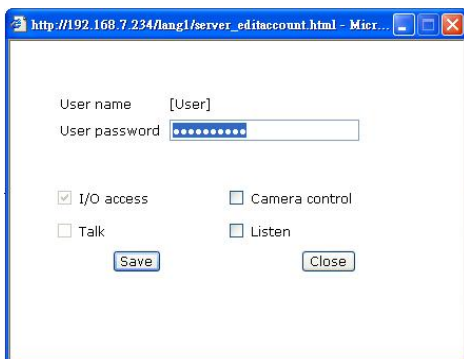

The screenshot shows a web browser window with the address bar displaying "http://192.168.7.234/lang1/server\_editaccount.html - Micr...". The main content area contains a form for editing user properties. The form has two text input fields: "User name" with the value "[User]" and "User password" with masked characters. Below these are four checkboxes: "I/O access" (checked), "Camera control", "Talk", and "Listen". At the bottom of the form are two buttons: "Save" and "Close".

## Network

Network	
<b>General</b>	
<input type="radio"/> Get IP address automatically	
<input checked="" type="radio"/> Use fixed IP address	
IP address	<input type="text" value="10.253.253.172"/>
Subnet mask	<input type="text" value="255.0.0.0"/>
Default gateway	<input type="text" value="10.0.0.51"/>
Primary DNS	<input type="text" value="10.0.0.19"/>
Secondary DNS	<input type="text" value="10.0.0.55"/>
<input type="radio"/> Use PPPoE	
User name	<input type="text"/>
Password	<input type="password"/>
<input type="button" value="Save"/>	
<b>Advanced</b>	
Web Server port	<input type="text" value="80"/>
RTSP port	<input type="text" value="554"/>
MJPEG over HTTP port	<input type="text" value="8008"/>
HTTPS port	<input type="text" value="443"/>
<input type="button" value="Save"/>	
<b>IPv6 Address Configuration</b>	
<input type="checkbox"/> Enable IPv6	Address :
<input type="button" value="Save"/>	

You can choose to use a fixed IP address or dynamic (DHCP) IP address for the camera.

## Get IP address automatically (DHCP)

The camera comes preconfigured with a fixed IP address.

**Note** Each camera has a unique Media Access Control (MAC) address, which can be used to identify the camera on the network. Record the IP Camera's MAC address, which can be found using the Surveillix Device search application and on the label of the camera, for identification in the future.

## Use Fixed IP Address

To set up a new static IP address:

1. Select the Use fixed IP address option.
2. Type a new IP address in the **IP address** box.
3. Type a new address in the **Default Gateway** box.
4. Click **Save** to confirm the new setting.

When using static IP address to log in to the IP Camera, you can access it either through Surveillix Device search software or type the IP address directly in the address bar of your Internet Explorer.

### General

- **IP address** – The IP Address is necessary for network identification.
- **Subnet mask** – Used to determine if the destination is in the same subnet. The default value is 255.255.255.0.
- **Default gateway** – Used to forward frames to destinations on different subnets or for internet access.
- **Primary DNS** – The primary domain name server that translates hostnames into IP addresses.
- **Secondary DNS** – A secondary domain name server that backups the primary DNS.

### Advanced

- **Web Server port** – Defines the port that Internet Explorer uses to connect over the web and view video. If this port is changed then the new port must be defined when attempting to web connect (ex: if your camera's IP address is 192.168.0.100 and you change the web port to 8001, then you must type http://192.168.0.100:8001 in your browser).

**Note** This is also the port used in Surveillix Server Software.

- **RTSP port** – The default RTSP port is 554; setting range: 1024 ~65535.
- **MJPEG over HTTP port** – The default HTTP Port is 8008; setting range: 1024 ~65535.
- **HTTPS port** – The default HTTPS Port is 443; setting range: 1024 ~65535.

**Note** No port number can be used in duplication on more than one item.

### IPv6 Address Configuration

To enable IPv6 select **Enable IPv6** and click **Save**. See your network administrator if you are unsure of your network configuration.

## QoS (Quality of Service)

---

Quality of Service allows you to prioritize network traffic services of the camera's functions. The QoS function utilizes the Differentiated Services prioritized using Codepoint values (DSCP).

**Note** Routers and switches on the network must be QoS or DSCP capable, and have these settings enabled for this function to operate on your network.

### DSCP Settings

The DSCP value range is 0 to 63. The default value is 0, which indicates the function is disabled; and rates 1 as the highest priority, and 63 as the lowest priority.

- **Video DSCP:** prioritize video streaming over HTTP or RTSP
- **Audio DSCP:** prioritize audio streaming
- **Management DSCP:** prioritize web interface traffic over HTTP

## SNMP

---

With Simple Network Management Protocol (SNMP) enabled, the camera can be monitored and managed remotely with a network management system. Contact your network administrator if you are not familiar with SNMP setup.

### SNMP v1/v2

- **Enable SNMP v1**
- **Enable SNMP v2**
- **Read Community:** Specify the community name that has read-only access.
- **Write Community:** Specify the community name that has read/write access.

### Traps for SNMP v1/v2

Traps are used to send a message to the network management system for important events or status changes.

- **Enable Traps:** enables trap reporting
- **Trap Address:** enter the IP address of the network management system
- **Trap Community:** enter the community to use when sending trap messages

## UPnP (Universal Plug and Play)

---

- **Enable UPnP:** When enabled the camera will appear in My Network Places on Windows computers running UPnP on the same network.
- **Enable UPnP Port Forwarding:** When enabled the camera will attempt to open the web server port on the router automatically.
- **Friendly Name:** Set a name to easily identify the camera.

## DDNS

DDNS (Dynamic Domain Name Service) is a service that allows a connection to an IP address using a hostname (URL) address instead of a numeric IP address. Most Internet Service Providers use Dynamic IP Addressing that frequently changes the public IP address of your internet connection; this means when connecting to the camera over the internet you need to know if your IP address has changed. DDNS automatically redirects traffic to your current IP address when using the hostname address.

The screenshot shows a web interface with a navigation bar at the top containing 'Home', 'System', 'Streaming', 'PTZ', and 'Logout'. On the left is a sidebar menu with items: System, Security, Network, DDNS, Mail, FTP, HTTP, Application, Motion detection, Storage management, Recording, File location, View log file, View user information, View parameters, Factory default, Software version, and Software upgrade. The main content area is titled 'DDNS' and contains the following configuration options:

- Dynamic DNS**  
Use Dynamic DNS If You Want To Use Your DDNS Account.
- Enable DDNS
- Provider: DynDNS.org(Dynamic) (dropdown menu)
- Host name: (text input field)
- Username/E-mail: (text input field)
- Password/Key: (text input field)
- Save (button)

- **Enable DDNS** – Select the check box to enable DDNS.
- **Provider** – Select a DDNS host from the Provider list.
- **Host name** – Type the registered domain name in the field.
- **Username/E-mail** – Type the username or e-mail required by the DDNS provider for authentication.
- **Password/Key** – Type the password or key required by the DDNS provider for authentication.

# Mail

The camera can send an e-mail via Simple Mail Transfer Protocol (SMTP) when motion is detected or when the sensor input is activated. SMTP is a protocol for sending e-mail messages between servers. SMTP is a relatively simple, text-based protocol, where one or more recipients of a message are specified and the message text is transferred.

SMTP	
1st SMTP (mail) server	<input type="text"/>
1st SMTP (mail) server port	<input type="text" value="25"/>
1st SMTP account name	<input type="text"/>
1st SMTP password	<input type="text"/>
1st recipient email address	<input type="text"/>
2nd SMTP (mail) server	<input type="text"/>
2nd SMTP (mail) server port	<input type="text" value="25"/>
2nd SMTP account name	<input type="text"/>
2nd SMTP password	<input type="text"/>
2nd recipient email address	<input type="text"/>
Sender email address	<input type="text"/>

Two sets of SMTP accounts can be configured. Each set includes SMTP Server, Account Name, Password and E-mail Address settings. For specific SMTP server information, contact your network service provider.

## FTP

Home System Streaming PTZ Logout

System  
Security  
Network  
DDNS  
Mail  
FTP  
HTTP  
Application  
Motion detection  
Storage management  
Recording  
File location  
View log file  
View user information  
View parameters  
Factory default  
Software version  
Software upgrade

**FTP**

1st FTP server

1st FTP server port

1st FTP user name

1st FTP password

1st FTP remote folder

1st FTP passive mode

2nd FTP server

2nd FTP server port

2nd FTP user name

2nd FTP password

2nd FTP remote folder

2nd FTP passive mode

Save

The camera can send alarm messages to a specific File Transfer Protocol (FTP) site when motion is detected or when the sensor input is activated. You can assign alarm messages to up to two FTP sites.

- Enter the FTP details, which include server, server port, user name, password and remote folder, in the appropriate boxes and click **Save** when finished.

## HTTP

The screenshot shows a web interface with a dark blue header containing navigation links: Home, System (selected), Streaming, PTZ, and Logout. On the left is a vertical menu with categories: System, Security, Network, DDNS, Mail, FTP, HTTP, Application, Motion detection, Storage management, Recording, File location, View log file, View user information, View parameters, Factory default, Software version, and Software upgrade. The main content area is titled 'HTTP' and contains the following configuration fields:

1st HTTP server	<input type="text"/>
1st HTTP user name	<input type="text"/>
1st HTTP password	<input type="password"/>
2nd HTTP server	<input type="text"/>
2nd HTTP user name	<input type="text"/>
2nd HTTP password	<input type="password"/>

At the bottom right of the form is a 'Save' button.

The camera can send alarm messages to a specific Hypertext Transfer Protocol (HTTP) site when motion is detected or when the sensor input is activated. You can assign alarm messages to up to two HTTP sites.

- Enter the HTTP details, which include server, user name and password, in the appropriate boxes and click **Save** when finished.

## Application

The IKS-WP816R supports 4 digital alarm inputs and 2 digital alarm outputs. Make sure the alarm connections are properly wired before starting to configure alarm related settings on the Application screen. Refer to the pin definition table below for alarm system wiring.

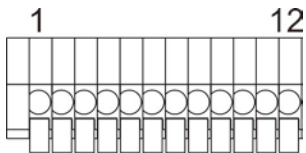

Pin	Definition
1	Alarm OUT NO 1
2	Alarm OUT NC 1
3	Alarm OUT COM 1
4	GROUND
5	Alarm OUT NO 2
6	Alarm OUT NC 2
7	Alarm OUT COM 1
8	GROUND
9	Alarm IN 4
10	Alarm IN 3
11	Alarm IN 2
12	Alarm IN 1

## Alarm Pin Selection

Home System Streaming PTZ Logout

System  
Security  
Network  
DDNS  
Mail  
FTP  
HTTP  
Application  
Motion detection  
Storage management  
Recording  
File location  
View log file  
View user information  
View parameters  
Factory default  
Software version  
Software upgrade

Application

Alarm pin selection

Alarm	Switch	Type
1.	Off	Normal close
2.	Off	Normal close
3.	Off	Normal close
4.	Off	Normal close

Edit

Select an alarm pin from the **Alarm Pin Selection** box and click **Edit** to start alarm programming.

# Alarm Pin Status Settings

Home System Streaming PTZ Logout

System  
Security  
Network  
DDNS  
Mail  
FTP  
HTTP  
Application  
Motion detection  
Tampering  
Storage management  
Recording  
File location  
View log file  
View user information  
View parameters  
Factory default  
Software version  
Software upgrade  
Maintenance

**Application**

**Alarm pin selection**

Alarm	Switch	Type
1.	Off	Normal close
2.	Off	Normal close
3.	Off	Normal close
4.	Off	Normal close

Edit

**Alarm pin1 status**

**Alarm setting**

Alarm switch Off Alarm type Normal close

**Triggered action**

- Enable alarm output
- Send message by FTP
- Upload image by FTP
- PTZ Function
- Record stream to sd card
- Enable alarm output 2
- Send message by E-Mail
- Upload image by E-Mail
- Send HTTP notification

**File name**

File name : image.jpg

- Add date/time suffix
- Add sequence number suffix (no maximum value)
- Add sequence number suffix up to 0 and then start over
- Overwrite

Save

## Alarm Setting

- **Alarm Switch** – Enable or disable the alarm function.
- **Alarm Type** – Select an alarm type (Normal Close or Normal Open) that corresponds with the alarm application.

## Trigger Action (Multi-Option)

Specify alarm actions that will take place when the alarm is triggered.

- **Enable Alarm Output** – Select this option to activate the alarm output.
- **Record Stream to SD Card** – Select this option to record to an internally installed SD card when this alarm is activated.

- **PTZ Function** – Assign a PTZ function (Preset, Tour, Auto Scan or Pattern) for the camera to perform when this alarm is activated.

**Note** If Preset is selected, you will be prompted to enter a Dwell Time (1~256). This is the time in seconds that the camera will remain at that Preset location, and then it will return to the location that it was pointing at the time the alarm occurred.

**Note** Refer to the sections on Presets, Tours, Auto Scans, or Patterns later in this manual for more details.

- **Send Message by FTP/E-Mail** – Select to send an alarm message by FTP and/or E-Mail when this alarm is activated.
- **Upload Image by FTP/E-Mail** – Select to send an image by FTP and/or E-Mail when this alarm is activated.
- **Send HTTP Notification** – Select to send a notification to a HTTP server.

**Note** E-Mail, FTP, and HTTP options will also need to be configured within their corresponding menus. See the Mail, FTP or HTTP sections previously in this manual for more details.

### **File Name**

Enter a file name in the box (the examples below used “image.jpg” for the file name). The uploaded image’s file name format can be set in this section. Please select the one that meets your requirements.

- **Add date/time suffix**  
File name: imageYYMMDD\_HHNNSS\_XX.jpg  
Y: Year, M: Month, D: Day  
H: Hour, N: Minute, S: Second  
X: Sequence Number
- **Add sequence number suffix (no maximum value)**  
File name: imageXXXXXXX.jpg  
X: Sequence Number
- **Add sequence number suffix (limited value)**  
File Name: imageXX.jpg  
X: Sequence Number  
The file name suffix will end at the number being set. For example, if the setting is up to “10”, the file name will start from 00 and end at 10, and then start all over again.
- **Overwrite** – The original image on the FTP site will be overwritten by the new uploaded file with a static filename.

## Motion Detection

Motion Detection allows the camera to detect motion and trigger alarms when motion in the detected area exceeds the determined sensitivity threshold value.

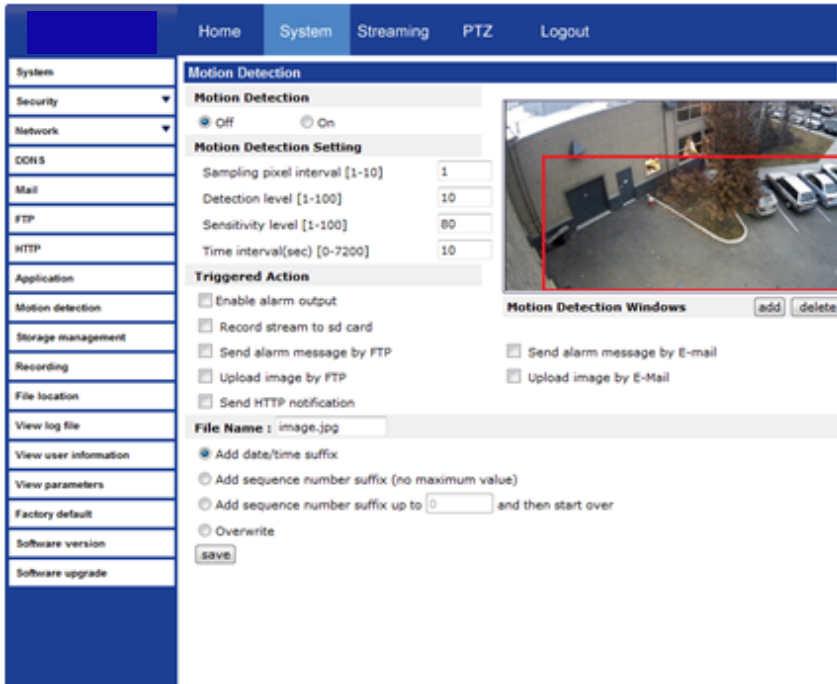

On the Motion Detection page, there is a motion detection window (red box) displayed on the Live View Pane. The Motion Detection window defines the motion detection area. To change the size of the Motion Detection window, drag the edge of the frame to resize.

You can add up to 10 motion detection windows.

- Click **Add** under the Live View Pane to add a Motion Detection window.
- To delete a Motion Detection window, use the mouse to select the frame and click **delete**.

When motion detection is activated, the **Motion** pop-up window will open.

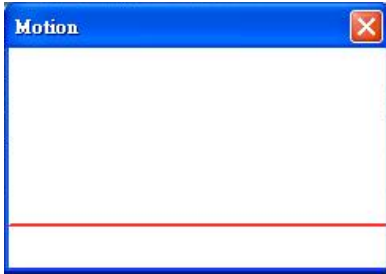

When motion is detected, the signals will be displayed on the Motion window as shown below

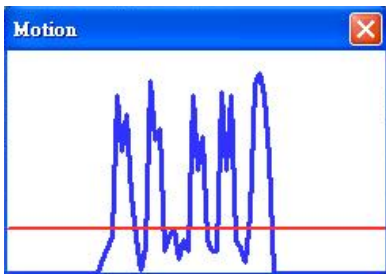

### **Motion Detection**

Turn motion detection on or off. The default setting is **Off**.

### **Motion Detection Setting**

In the Motion window the red line provides a motion detection threshold indication; and the blue line provides a representation of motion being detected. For the camera to register a motion event, the blue line must move above the red line. After changing any of these four settings you must click **Save** to apply the change.

- **Sampling pixel interval [1-10]** – Default value is 10, which means system will take one sampling pixel for every 10 pixels.
- **Detection level [1-100]** – Default detection level is 10. This item sets the detection level for each sampling pixel; the smaller the value, the more sensitive it is.
- **Sensitivity level [1-100]** – The default sensitivity level is 80, which means if 20% or more sampling pixels are detected as changed, the system will detect motion. The bigger the value, the more sensitive it is. As the sensitivity value is increased, the red horizontal line in the motion indication window will be lowered accordingly.
- **Time interval (sec) [0-7200]** – The default interval is 10. The value is the interval between each detected motion event.

## Triggered Action

Once motion detection has been fine tuned, the Triggered Action can be configured if you want the camera to take one of these actions upon sensing motion.

- **Enable Alarm Output** – Select to trigger the alarm output on the camera on motion detection.
- **Record Stream to SD Card** – Select this option to record to an internally installed SD card when this alarm is activated.
- **Send Alarm Message by FTP/E-Mail** – Select to send an alarm message by FTP and/or E-Mail when this alarm is activated.
- **Upload Image by FTP/E-Mail** – Select to send an image by FTP and/or E-Mail when this alarm is activated.
- **Send HTTP Notification** – Select to send a notification to a HTTP server.

**Note** E-Mail, FTP, and HTTP options will also need to be configured within their corresponding menus. See the Mail, FTP or HTTP sections previously in this manual for more details.

**File Name** – Enter a file name in the box (the examples below used “image.jpg” for the file name). The uploaded image’s file name format can be set in this section. Please select the one that meets your requirements.

- **Add date/time suffix**  
File name: imageYYMMDD\_HHNNSS\_XX.jpg  
Y: Year, M: Month, D: Day  
H: Hour, N: Minute, S: Second  
X: Sequence Number
- **Add sequence number suffix (no maximum value)**  
File name: imageXXXXXXXXX.jpg  
X: Sequence Number
- **Add sequence number suffix (limited value)**  
File Name: imageXX.jpg  
X: Sequence Number  
The file name suffix will end at the number being set. For example, if the setting is up to “10”, the file name will start from 00 and end at 10, and then start all over again.
- **Overwrite** – The original image on the FTP site will be overwritten by the new uploaded file with a static filename.

## Storage Management

Storage Management allows you to view information about an inserted Micro SD/SDHC card (up to 32GB), format the SD card, adjust cleanup settings, and download or delete files stored on the SD card.

The screenshot shows the 'Storage Management' page in a web interface. The top navigation bar includes 'Home', 'System', 'Streaming', 'PTZ', and 'Logout'. The left sidebar contains a menu with items like System, Security, Network, DDNS, Mail, FTP, HTTP, Application, Motion detection, Storage management, Recording, File location, View log file, View user information, View parameters, Factory default, Software version, and Software upgrade. The main content area is titled 'Storage Management' and is divided into three sections: 'Device information', 'Device setting', and 'Disk cleanup setting'. The 'Device information' section shows 'Device type: SD card', 'Free space: 0 KB', 'Total size: 0 KB', and 'Status: No'. The 'Device setting' section has a 'Format device:' label and a 'Format' button. The 'Disk cleanup setting' section has a checkbox for 'Enable automatic disk cleanup', a 'Remove recordings older than:' field with a value of '1' and a 'day(s)' dropdown, and a 'Remove oldest recordings when disk is:' field with a value of '85' and a '% full' label. Below these settings is a 'Recording list' section with a table header showing 'FileName' and 'Size', and buttons for 'Remove', 'Sort', and 'Download'.

**Device Information** – When a compatible Micro SD/SDHC card is inserted into the camera, information about the card will be displayed in this section.

**Device Setting** – The Micro SD/SDHC card can be formatted using the **Format** button. A newly inserted card should always be formatted upon insertion before recording to it is configured.

**Disk Cleanup Setting** – An automatic cleanup can be configured so that once the available storage on the Micro SD/SDHC card reaches a percentage of use, older items will be removed. To enable Disk Cleanup:

1. Select **Enable automatic disk cleanup**.
2. Enter a percentage of use threshold needed to trigger the cleanup.
3. Enter a number of days or weeks as a deletion point
4. Data older than the specified number of days or weeks will be automatically deleted when the percentage of use threshold is triggered.

**Recording List** - Each file recorded to the Micro SD/SDHC card will be listed in the Recording List.

*Note* The maximum file is 60MB per file.

*Note* The letters A/M/R appear at the beginning of each file, denoting the type of recording. A for alarm; M for motion; and R for regular recording.

- To remove a file, select the file from the list and click **Remove**.
- Click **Sort** to sort the list.
- To download a file, select the file from the list and click **Download**.

## Recording

The recording schedule allows you to set up scheduled recording to a local Micro SD/SDHC card.

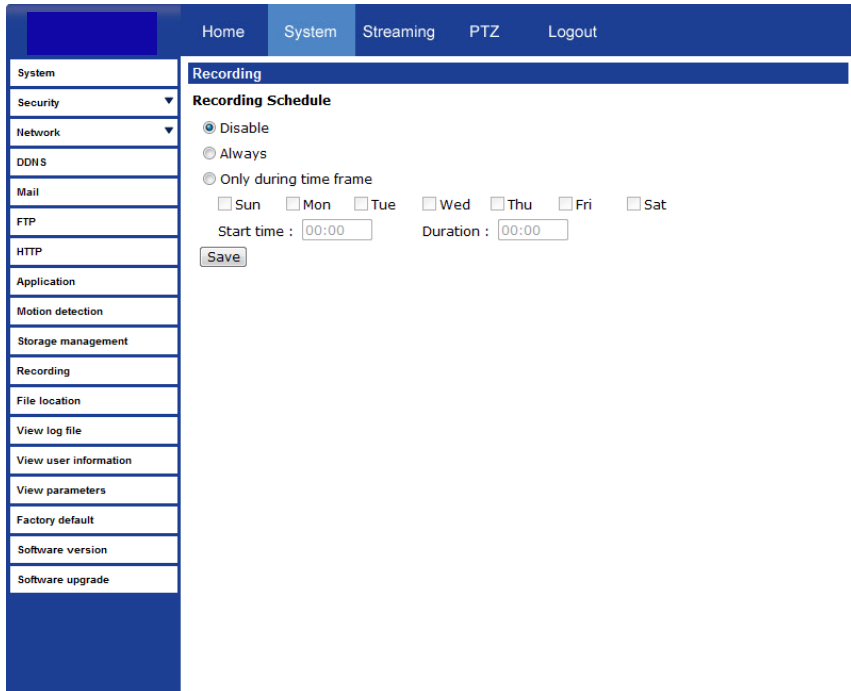

The screenshot shows a web interface with a navigation menu at the top containing 'Home', 'System', 'Streaming', 'PTZ', and 'Logout'. The 'System' menu is expanded on the left, listing various settings like Security, Network, DDNS, Mail, FTP, HTTP, Application, Motion detection, Storage management, Recording, File location, View log file, View user information, View parameters, Factory default, Software version, and Software upgrade. The main content area is titled 'Recording' and contains a 'Recording Schedule' section. It features three radio button options: 'Disable' (selected), 'Always', and 'Only during time frame'. Under 'Only during time frame', there are checkboxes for each day of the week: Sun, Mon, Tue, Wed, Thu, Fri, and Sat. Below these are input fields for 'Start time' and 'Duration', both set to '00:00'. A 'Save' button is located at the bottom of the configuration area.

## Activating Micro SD/SDHC Card Recording

To set up continuous micro SD/SDHC card recording:

1. Select **Always** to continually record until the card is full.
2. To set the camera to overwrite old data, see the instructions for Disk Cleanup Setting earlier in this section.

To create a recording schedule:

1. Select **Only during time frame**.
2. Select the days of the week you want to record
3. Specify the **Start Time** and **Duration** of each recording.

To stop recording data to the micro SD/SDHC card, select **Disable**.

## Snapshot

The IKS-WP816R camera supports JPEG snapshot function. You can specify a storage location for the snapshots. The default setting is: C:\.

**Note** If you are using Windows Vista or 7, you will need to change the Snapshot location. Windows UAC does not allow internet programs to write directly to C:\ for security reasons.

**Note** Make sure the selected file path contains valid characters such as letters and numbers.

The screenshot displays the web interface of the IKS-WP816R camera. At the top, there is a navigation bar with tabs for Home, System, Streaming, PTZ, and Logout. The 'System' tab is selected. On the left side, there is a vertical menu with various system settings: System, Security, Network, DDNS, Mail, FTP, HTTP, Application, Motion detection, Storage management, Recording, File location, View log file, View user information, View parameters, Factory default, Software version, and Software upgrade. The 'File location' option is highlighted. The main content area is titled 'File Location' and contains the instruction 'Set the destination of snapshot photos and recorded video files'. Below this, there is a text input field labeled 'All files stored at:' with the value 'C:\' and a 'Select' button. A 'Save' button is located below the input field.

## Information

The **Information** page contains the System Log, User Information, and Parameter List.

## System Log

Click **System Log** to view the system log file. The content of the file provides useful information about configuration and connections.

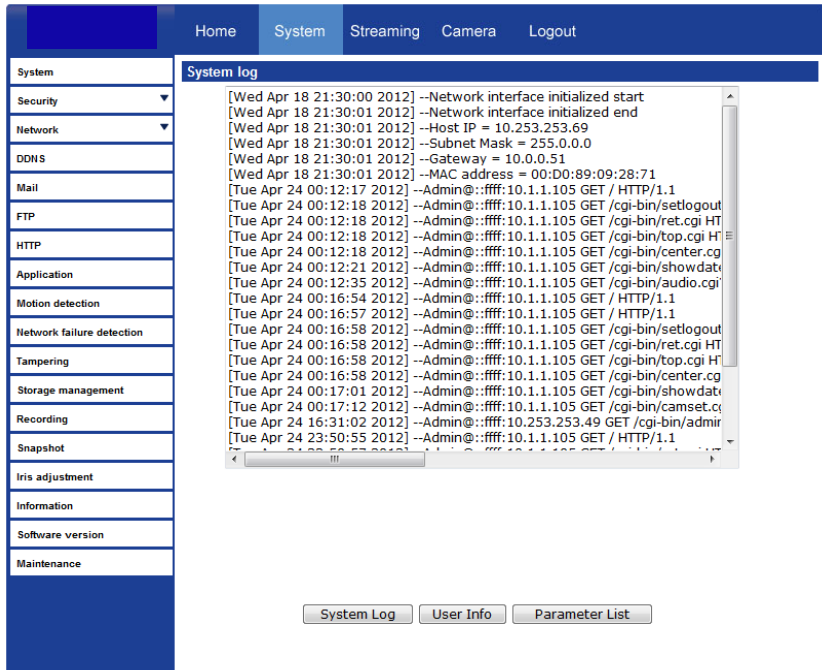

The screenshot shows a web interface with a navigation menu at the top containing 'Home', 'System', 'Streaming', 'Camera', and 'Logout'. On the left side, there is a vertical menu with various system settings: System, Security, Network, DDNS, Mail, FTP, HTTP, Application, Motion detection, Network failure detection, Tampering, Storage management, Recording, Snapshot, Iris adjustment, Information, Software version, and Maintenance. The 'System' menu item is selected, and the main content area displays the 'System log' with a list of system events. Each event includes a timestamp and a description of the action, such as network interface initialization, host IP assignment, and user login attempts. At the bottom of the page, there are three buttons: 'System Log', 'User Info', and 'Parameter List'.

System	System log
System	[Wed Apr 18 21:30:00 2012] --Network interface initialized start
Security	[Wed Apr 18 21:30:01 2012] --Network interface initialized end
Network	[Wed Apr 18 21:30:01 2012] --Host IP = 10.253.253.69
DDNS	[Wed Apr 18 21:30:01 2012] --Subnet Mask = 255.0.0.0
Mail	[Wed Apr 18 21:30:01 2012] --Gateway = 10.0.0.51
FTP	[Wed Apr 18 21:30:01 2012] --MAC address = 00:D0:89:09:28:71
HTTP	[Tue Apr 24 00:12:17 2012] --Admin@:ffff:10.1.1.105 GET / HTTP/1.1
Application	[Tue Apr 24 00:12:18 2012] --Admin@:ffff:10.1.1.105 GET /cgi-bin/setlogout
Motion detection	[Tue Apr 24 00:12:18 2012] --Admin@:ffff:10.1.1.105 GET /cgi-bin/ret.cgi HT
Network failure detection	[Tue Apr 24 00:12:18 2012] --Admin@:ffff:10.1.1.105 GET /cgi-bin/top.cgi H
Tampering	[Tue Apr 24 00:12:18 2012] --Admin@:ffff:10.1.1.105 GET /cgi-bin/center.cg
Storage management	[Tue Apr 24 00:12:21 2012] --Admin@:ffff:10.1.1.105 GET /cgi-bin/showdat
Recording	[Tue Apr 24 00:12:35 2012] --Admin@:ffff:10.1.1.105 GET /cgi-bin/audio.cgi
Snapshot	[Tue Apr 24 00:16:54 2012] --Admin@:ffff:10.1.1.105 GET / HTTP/1.1
Iris adjustment	[Tue Apr 24 00:16:57 2012] --Admin@:ffff:10.1.1.105 GET / HTTP/1.1
Information	[Tue Apr 24 00:16:58 2012] --Admin@:ffff:10.1.1.105 GET /cgi-bin/setlogout
Software version	[Tue Apr 24 00:16:58 2012] --Admin@:ffff:10.1.1.105 GET /cgi-bin/ret.cgi HT
Maintenance	[Tue Apr 24 00:16:58 2012] --Admin@:ffff:10.1.1.105 GET /cgi-bin/top.cgi H
	[Tue Apr 24 00:16:58 2012] --Admin@:ffff:10.1.1.105 GET /cgi-bin/center.cg
	[Tue Apr 24 00:17:01 2012] --Admin@:ffff:10.1.1.105 GET /cgi-bin/showdat
	[Tue Apr 24 00:17:12 2012] --Admin@:ffff:10.1.1.105 GET /cgi-bin/camsetc
	[Tue Apr 24 16:31:02 2012] --Admin@:ffff:10.253.253.49 GET /cgi-bin/admin
	[Tue Apr 24 23:50:55 2012] --Admin@:ffff:10.1.1.105 GET / HTTP/1.1

## View User Information

The Administrator can view each user's login information and privileges on the **View User Information** page

All the users in the network are listed under **User information**. The example below shows that the Admin password is 1234.

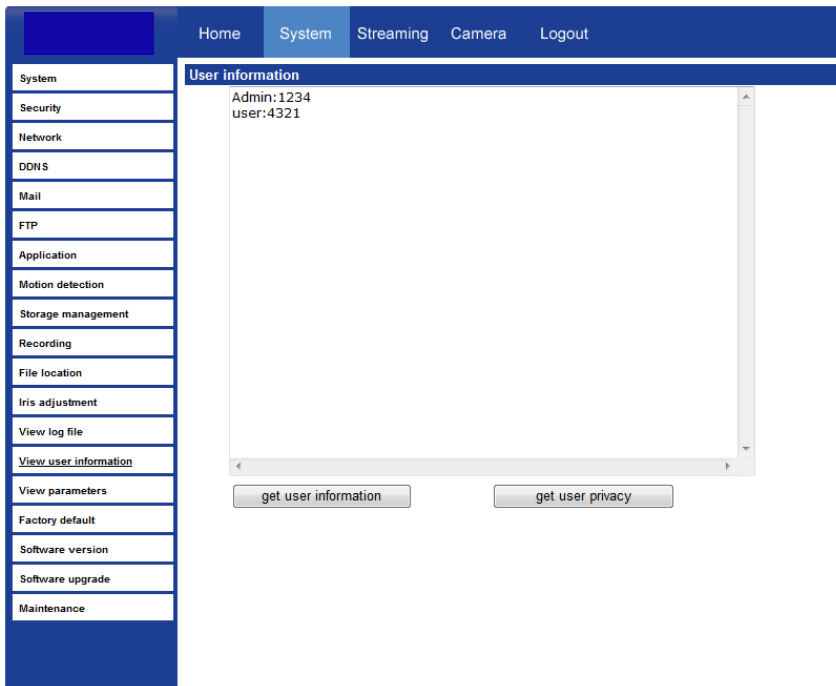

## View User Privilege

---

Select a user account from the list and click **get user privacy** to view the permissions for the user account.

## Parameter List

Click **Parameter List** to view the system parameter settings.

The screenshot shows a web interface with a dark blue header and a left-hand navigation menu. The main content area is titled "Parameter list" and displays the following settings:

```
Mega Pixel Camera Initial Configuration File
=====
[Camera setting]
=====
exposure mode = <auto>
min shutter speed = <5>
fixed shutter speed = <56>
white balance mode = <auto>
white balance rgain = <57>
white balance bgain = <54>
brightness value = <128>
sharpness value = <3>
contrast value = <64>
```

At the bottom of the interface, there are three buttons: "System Log", "User Info", and "Parameter List". The "Parameter List" button is highlighted in light blue.

## Software Upgrade

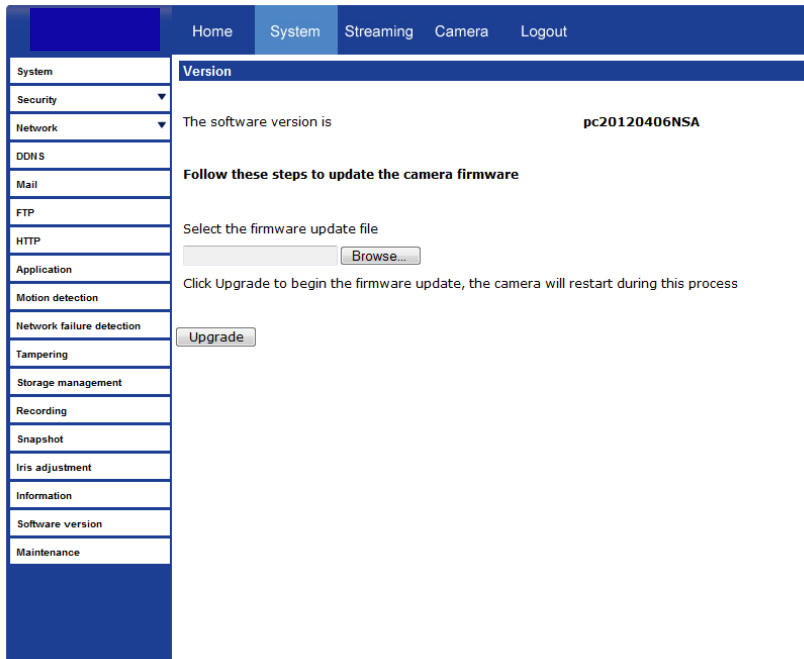

## Upgrading the Camera Viewer Software

**Note** Make sure the software upgrade file is available before starting the software upgrade.

1. Click **Browse** and find the upgrade file.

**Note** Do not change the file name, or the system will fail to find the file.

2. Select the file name from the list under **Step 2**.
3. Click **Upgrade**. The system will check to find the upgrade file, and then start to upload the upgrade file. The upgrade status bar will display on the page. When it reaches 100%, the viewer will return to Home page.
4. Close the internet browser.
5. Go to the **Windows Control Panel** and double-click **Add or Remove Programs**. Locate the **Camera Viewer** software on the **Currently installed programs** list and click **Remove** to uninstall the previous software version.
6. Open the internet browser again and log in to the IKS-WP816R. The system will automatically download the new version of the Camera Viewer software.

## Maintenance

On the Maintenance page you can export the camera's current configuration, or import the configuration for a camera. Use the factory default page to reset the IP camera to factory default settings if necessary.

**Note** Do not import configuration files from different models of cameras.

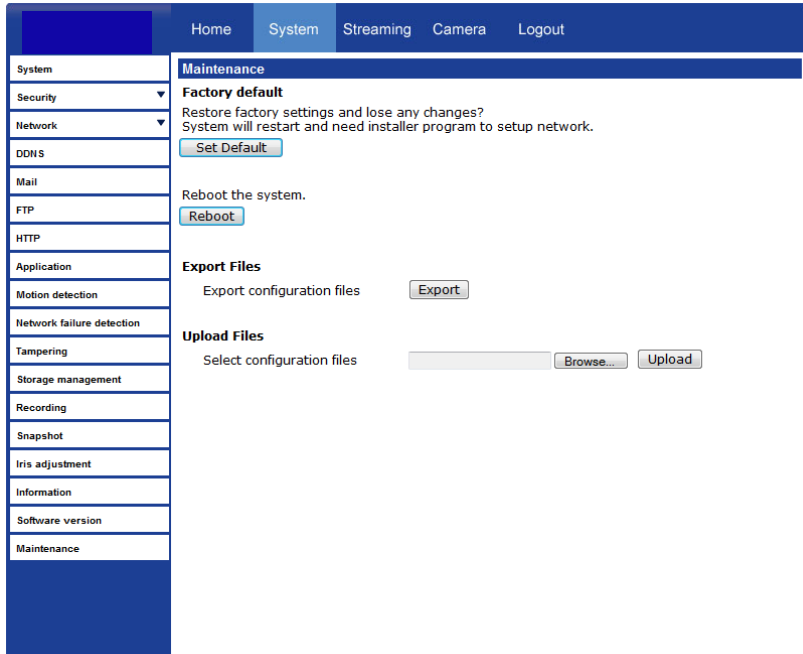

**Set Default** –To reset the IP camera to the factory default settings, including the default IP address, click Set Default. The system will restart after 30 seconds. If you cannot access the camera menu, you can return the camera to the factory default settings by holding down the reset menu button on the camera connection board for 30 seconds. See **Error! Reference source not found.** for the button location.

**Reboot** – To restart the IP camera without changing the current camera settings, Click **Reboot**.

**Export** – You can save the system settings by exporting the configuration file (.bin) to a specified location for future use. Click **Export**, then **Save**, and specify the desired location.

**Upload** – To copy an existing configuration file to the IP camera, click **Browse**, select the desired configuration file, then click **Upload**.

# Video and Audio Streaming Settings

On the Streaming tab, the Administrator can configure specific video resolution, video compression mode, video protocol, audio transmission mode, etc.

## Video Format

Select the desired video resolution for the camera on the Video Format page. The recorder will record video based on the resolution selected here.

The screenshot shows a web interface for configuring video streaming settings. The top navigation bar includes 'Home', 'System', 'Streaming', 'Camera', and 'Logout'. The left sidebar contains a menu with 'Video Format' selected, along with 'Video Compression', 'Video OCX Protocol', 'Frame Rate Control', 'Video Mask', and 'Audio'. The main content area is titled 'Video Format' and contains the following sections:

- Video Resolution :** A dropdown menu is set to 'H.264 + MJPEG'. Below it, 'H.264 format :' is set to '1920 x 1080 (15 fps)' and 'MJPEG format :' is set to '720 x 480 (30 fps)'. 'BNC support :' is set to 'Yes'. A 'Save' button is present.
- Note :** A text note stating 'Image attachment by FTP or E-mail will be available only while MJPEG streaming is selected.'
- Text Overlay Settings :** Includes checkboxes for 'Include date' and 'Include time', and a text input field for 'Include text string:'. A 'Save' button is present.
- Video Rotation:** A dropdown menu is set to 'Normal video'. A 'Save' button is present.
- GOP Settings :** Includes input fields for 'H.264-1 GOP Length : 60', 'H.264-2 GOP Length : 60', 'H.264-3 GOP Length : 30', and 'H.264-4 GOP Length : 30'. A 'Save' button is present.
- H.264 Profile :** Includes dropdown menus for 'H.264-1 : Main profile', 'H.264-2 : Main profile', 'H.264-3 : Main profile', and 'H.264-4 : Main profile'. A 'Save' button is present.

## Video Resolution

---

The camera provides four codec options under video resolution (two single streaming options and two sets of dual streaming options):

- MJPEG only
- H.264 only
- MJPEG + H.264
- H.264 + H.264

Once a codec option is selected, multiple resolutions are available for each stream.

MJPEG Resolutions*	H.264 Resolutions*
1920x1080	1920x1080
	1920x1080 (@ 15 FPS)
1280x1024	1280x1024
1280x720	1280x720
1024x768	1024x768
800x600	800x600
720x480	720x480
640x480	640x480
352x240	352x240

\*All resolutions are at 30 Frames Per Second (FPS) unless otherwise noted.

**Note** Due to resource management, some resolutions may be unavailable when selecting a dual stream option.

**Note** Due to resource management, the Motion Detection, 3DNR, and Privacy Mask functions are not available when using the **H.264 Only** codec option and selecting the **Low Latency** H.264 format.

## Text Overlay Settings

---

Text Overlay allows you to select text to be display over the video. Three options are available: Date, Time, and a Custom String (up to 20 alphanumeric characters).

## Video Rotate Type

---

You can change the orientation of the video output if necessary.

**Normal Video** – This is the default rotation designed for a normal setup with the camera mounted with the dome facing down.

**Flip Video** – This option will vertically flip the video image (without the intervention of another device this may cause the reversal of perceived left and right when viewing the image).

**Mirror Video** – This option will horizontally flip the video image (without the intervention of another device this may cause the reversal of perceived left and right when viewing the image).

**90 Degree Clockwise** – This option will rotate the video image 90 degrees to the right.

**180 Degree Rotate** – This option will rotate the video image 180 degrees (this is the option most commonly needed if the image appears upside-down when the camera is first installed).

**90 Degree Counterclockwise** – This option will rotate the video image 90 degrees to the left.

## GOP Settings

---

The Group of Pictures settings allow you to modify the frame structure of the video stream. This setting changes the frequency of the I-frames that occur within the stream of P-frames (2~64). Increasing this number increases the number of P-frames between each I-frame; decreasing the file size of the stream, but increasing the risk of video decoding errors. Decreasing this number decreases the number of P-Frames between each I-frame; increasing the file size of the stream, but decreasing the risk of video decoding errors.

## H.264 Profile

---

The H.264 Profile may need to be changed if you are using a third party recorder that is not capable of decoding H.264 Main Profile video compression. Select the compatible compression type for each stream if necessary.

## Video Compression

You can select an MJPEG/H.264 compression mode on the video compression page appropriate for your application. You can also select to display compression information on the Home page.

The screenshot shows a web interface with a navigation bar at the top containing 'Home', 'System', 'Streaming', 'PTZ', and 'Logout'. The 'Streaming' tab is active. On the left, a sidebar menu lists 'Video Format', 'Video Compression', 'Video OCX Protocol', 'Frame Rate Control', and 'Audio'. The 'Video Compression' section is expanded, showing the following settings:

- Video Compression**
  - MJPEG Compression setting :**
    - MJPEG Q factor :
    -
  - H.264-1 Compression setting :**
    - H264-1 bit rate :  kbit/s
    -
  - H.264-2 Compression setting :**
    - H264-2 bit rate :  kbit/s
    -
  - Compression information setting :**
    - Display compression information in the home page
    -
  - CBR mode setting :**
    - enable H.264-1 CBR mode
    - enable H.264-2 CBR mode
    -

### MJPEG Compression settings include:

- high compression, low bit rate, low quality
- middle compression, default
- low compression, high bit rate, high quality

### H.264 Compression settings include:

- 1024kbps, highest compression, lowest quality
- 2048kbps
- 4096kbps, middle compression, default
- 6144kbps
- 8192kbps, low compression, highest quality

### CBR Mode Setting

- The Constant Bit Rate mode allows you to lock in the bit rate of the H.264 stream. If this setting is not enabled bit rate may fluctuate based on available bandwidth.

# Video OCX Protocol

On the Video OCX protocol page, you can select different protocols for streaming media over the network. In the case of multicast networking, you can select the Multicast mode.

The screenshot shows a web interface with a navigation bar at the top containing 'Home', 'System', 'Streaming', 'PTZ', and 'Logout'. On the left is a sidebar menu with 'Video Format', 'Video Compression', 'Video OCX Protocol', 'Frame Rate Control', and 'Audio'. The main content area is titled 'Video OCX Protocol' and contains the following settings:

- Video OCX protocol setting :**
  - RTP over UDP
  - RTP over RTSP(TCP)
  - RTSP over HTTP
  - MJPEG over HTTP
  - Multicast mode
    - Multicast IP Address:
    - Multicast H.264-1 Video Port:
    - Multicast H.264-2 Video Port:
    - Multicast MJPEG Video Port:
    - Multicast Audio Port:
    - Multicast TTL:

Below the settings is a 'Save' button and a note: 'Note: This page only applies to video streams going to a DC Viewer.'

Video OCX protocol setting options include:

- RTP over UDP
- RTP over RTSP(TCP)
- RTSP over HTTP
- MJPEG over HTTP

Select a mode according to your data delivery requirements. If you are transmitting over the internet using a router and port forwarding, you need to use RTP over RTSP(TCP). You also need to forward the RTSP port to the camera (see the Network Setup page to find the RTSP port).

## Multicast Mode

1. Enter all required data, including multicast IP address, H.264 video port, MJPEG video port, audio port and TTL into each box.
2. Click Save to confirm the setting.

## Frame Rate Control

Setting the camera to transmit fewer frames can save bandwidth.

The screenshot shows a web interface for configuring video settings. At the top, there is a navigation bar with tabs for Home, System, Streaming, PTZ, and Logout. On the left side, there is a vertical menu with options: Video Format, Video Compression, Video OCX Protocol, Frame Rate Control (which is currently selected), and Audio. The main content area is titled 'Frame Rate Control' and contains three sections for setting frame rates:

- MJPEG Frame Rate Setting:** A text input field labeled 'MJPEG frame rate :' with the value '30' and a 'Save' button below it.
- H264-1 Frame Rate Setting:** A text input field labeled 'H264-1 frame rate :' with the value '30' and a 'Save' button below it.
- H264-2 Frame Rate Setting:** A text input field labeled 'H264-2 frame rate :' with the value '30' and a 'Save' button below it.

Each of the MJPEG and H.264 streams can have a separate frame rate setting from 1 to 30 frames per second.

**Note** Higher frame rate will increase video smoothness, as well as file size and bandwidth usage.

**Note** Lower frame rate will decrease video smoothness, as well as file size and bandwidth usage.

## Audio

On the audio page, the Administrator can select an audio transmission mode and audio bit rate.

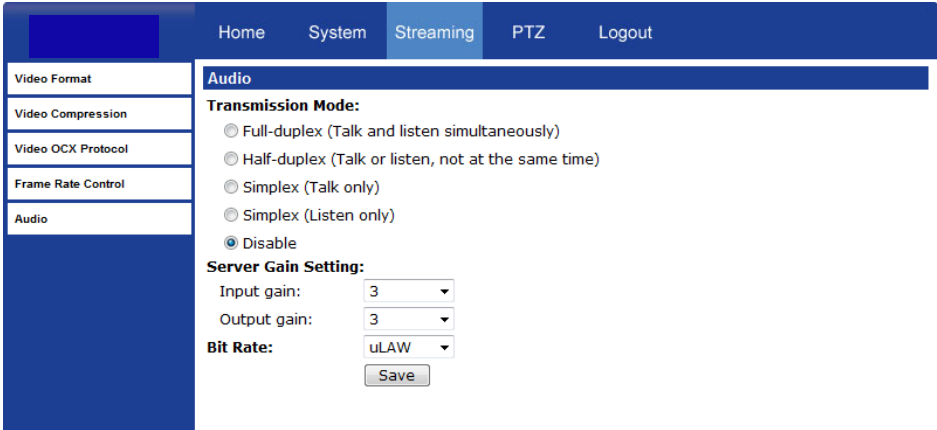

The screenshot shows a web interface with a navigation bar at the top containing 'Home', 'System', 'Streaming', 'PTZ', and 'Logout'. On the left, there is a sidebar menu with options: 'Video Format', 'Video Compression', 'Video OCX Protocol', 'Frame Rate Control', and 'Audio'. The 'Audio' page is active, displaying the following settings:

- Transmission Mode:**
  - Full-duplex (Talk and listen simultaneously)
  - Half-duplex (Talk or listen, not at the same time)
  - Simplex (Talk only)
  - Simplex (Listen only)
  - Disable
- Server Gain Setting:**
  - Input gain: 3
  - Output gain: 3
- Bit Rate:** uLAW
- 

**Note** Audio monitoring and recording laws vary from location to location. It is highly recommended that you consult your local, state, and federal laws to verify that you are in compliance before implementing audio recording.

## Transmission Mode

- **Full-duplex (Talk and Listen simultaneously)** – In Full-duplex mode, the local and remote sites can communicate with each other simultaneously, i.e. both sites can speak and be heard at the same time.
- **Half-duplex (Talk or Listen, not at the same time)** – In Half-duplex mode, the local/remote site can only talk or listen to the other site at a time.
- **Simplex (Talk only)** – In Talk only Simplex mode, the local/remote site can only talk to the other site
- **Simplex (Listen only)** – The local/remote site can only listen to the other site.
- **Disable** – Turn off the audio transmission function.

## Server Gain Settings

Set the audio input/output gain levels for sound amplification. The audio gain values are adjustable from 1 to 6, and will be turned off if 'Mute' is selected.

## Bit Rate

---

Selectable audio transmission bit rate include:

16 kbps (G.726)

40 kbps (G.726)

24 kbps (G.726)

uLAW (G.711)

32 kbps (G.726)

ALAW (G.711).

Both uLAW and ALAW signify 64 kbps but in different compression formats. Higher bit rate will provide higher audio quality and require more bandwidth.

# PTZ SETTINGS

Use the PTZ tab to program Presets, Patterns, Auto Scans and Tours via PTZ controls. Additionally, various camera settings including Auto Exposure (AE), White Balance (WB), Back Light Compensation (BLC), Sharpness, Exposure Compensation, etc. also can be set here.

## Preset

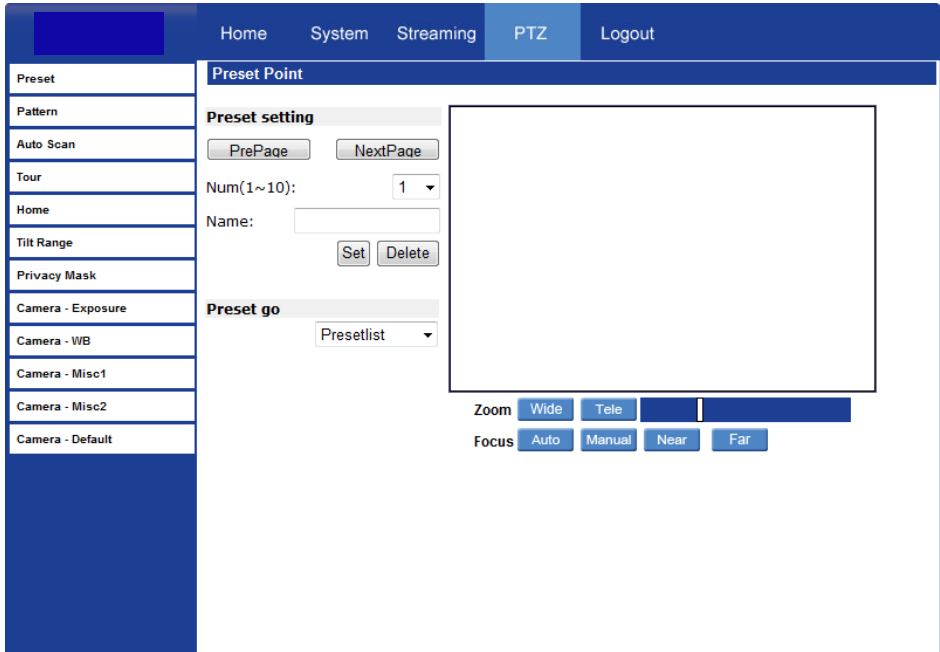

**Note** Up to 256 Presets can be programmed for the camera.

### ***Preset Setting***

To create a Preset Point:

1. Move the pointer to the live view pane.
2. Drag the red pointer with PTZ controls to a desired position.
3. Assign a number for the current position from the **Number List** (1~10) and type a descriptive **Name**.
4. Click **Set** to save the settings.

## Preset Go

To move the camera view to a specified Preset position:

- Select the Preset Point from the list under **Preset Go**. The camera will move to the target position.

## Pattern

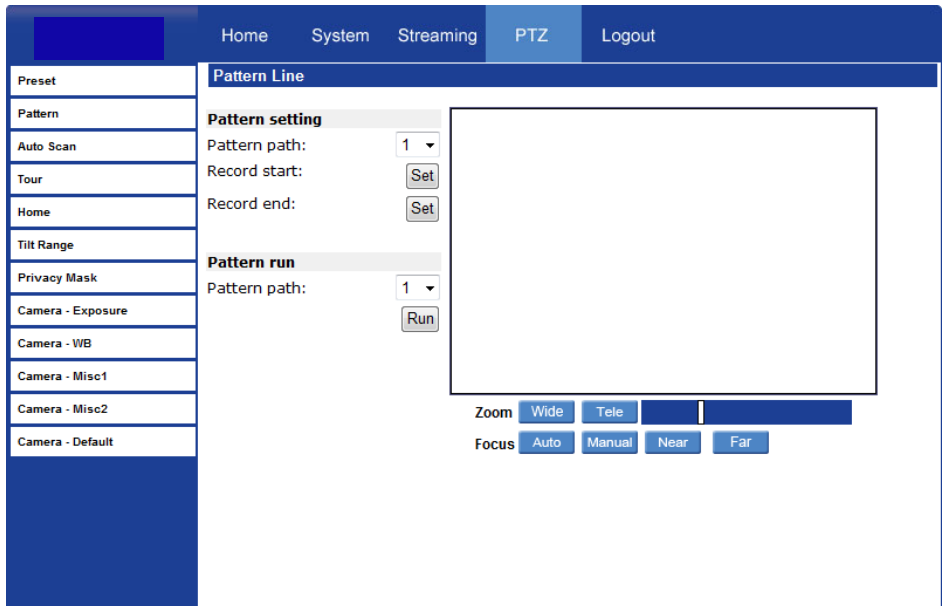

**Note** The camera supports up to eight patterns.

### Pattern Setting

To create a Pattern:

1. Select a path number from the **Pattern Path** list.
2. Move the pointer to the live view pane, and move the camera to a desired view using the PTZ controls for the start point of a Pattern.
3. Click **Set** next to **Record Start** and start programming the Pattern via the PTZ controls.
4. When you have finished the pattern, click **Set** next to **Record End**. The Pattern will be automatically recorded.

## Pattern Run

Select the specified Pattern from the Pattern Path list and click **Run**.

To view the camera in full screen mode, move the pointer onto the live view pane, right-click and select **Fullscreen**.

To stop running a Pattern, move the cursor to the live view pane and use the PTZ controls to move the camera in any direction.

## Auto Scan

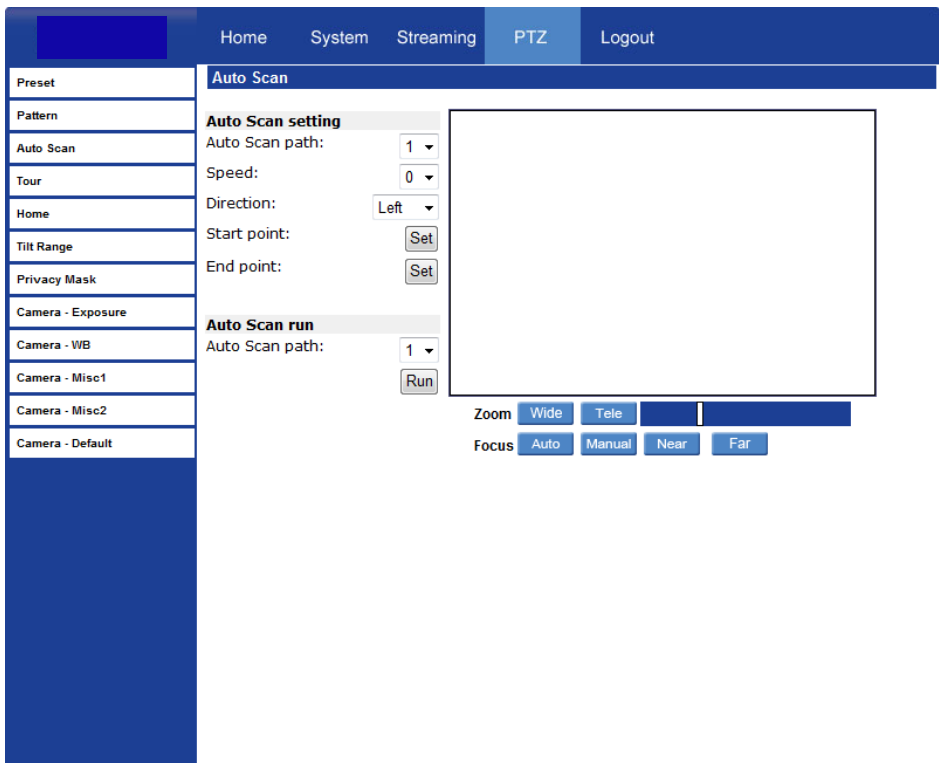

The screenshot displays the PTZ control interface. At the top, there is a navigation bar with tabs for Home, System, Streaming, PTZ (selected), and Logout. On the left side, there is a vertical menu with options: Preset, Pattern, Auto Scan, Tour, Home, Tilt Range, Privacy Mask, Camera - Exposure, Camera - WB, Camera - Misc1, Camera - Misc2, and Camera - Default. The main content area is titled "Auto Scan" and contains two sections: "Auto Scan setting" and "Auto Scan run".

**Auto Scan setting**

- Auto Scan path: 1
- Speed: 0
- Direction: Left
- Start point: Set
- End point: Set

**Auto Scan run**

- Auto Scan path: 1
- Run

Below the settings and run buttons, there is a large empty rectangular area representing the live view. At the bottom of the interface, there are PTZ controls: Zoom (Wide, Tele, a slider bar, and a button) and Focus (Auto, Manual, Near, Far).

**Note** The camera supports four Auto Scan paths.

## ***Auto Scan Setting***

To create an Auto Scan path:

1. Select a path number from the **Auto Scan Path** list.
2. Move the pointer to the live view pane, and move the camera to a desired view as the Start Point of an Auto Scan Path.
3. Click the “Set” button of the “Start Point”, and the current view will be automatically saved as the start point of the Auto Scan Path.

**Note** The room ratio of an Auto Scan’s Start Point will persist throughout the whole path.

4. Enter the speed ratio in the **Speed** box; the speed ratio ranges from 0 (low) to 3 (fast).
5. Select the **Direction** of the Auto Scan Path, (Left or Right).
6. Move the camera to the desired end point position and click **Set** next to **End Point**.

## ***Auto Scan Run***

Select the specified path from the list under **Auto Scan Run** and click **Run**.

To view the camera in full screen mode, move the cursor onto the live view pane, right-click and select **Fullscreen**.

To stop running an Auto Scan Path, move the cursor to the live view pane and use the PTZ controls to move the camera in any direction.

# Tour

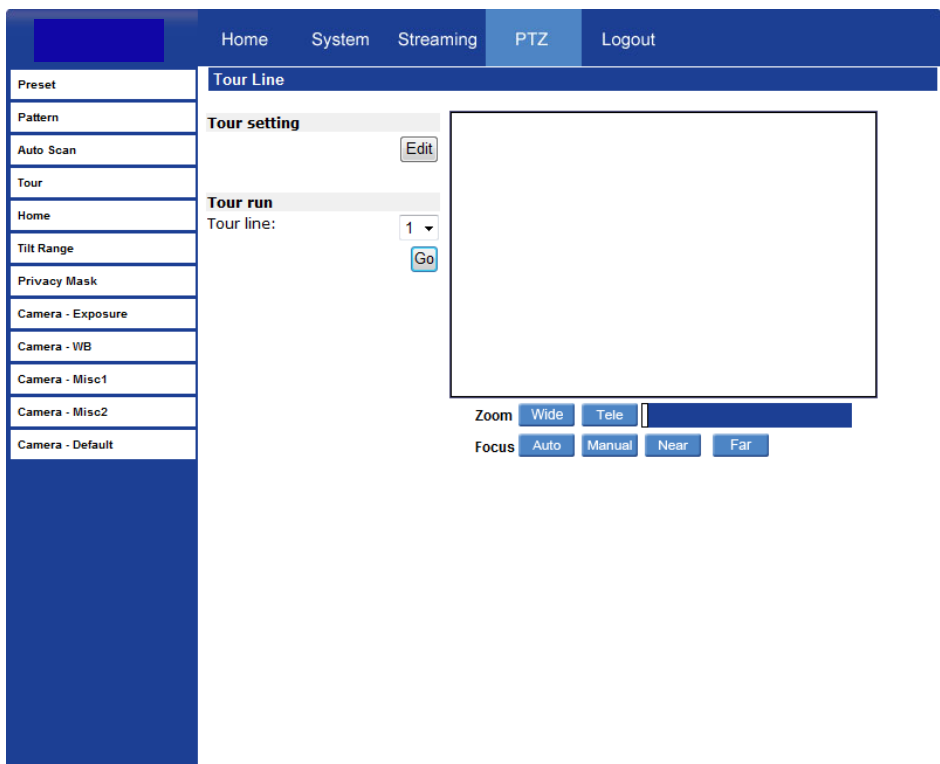

The camera supports up to eight Tours; each Tour supports up to 64 Presets.

**Note** Before setting this function, you must pre-define at least two Presets.

## Tour Set

Preset	Name	Dwell time	Speed
1.	3(office)	10	14
2.	1(door)	30	7
3.	3(office)	10	14
4.	2(door2)	30	7
5.	--no setting--		
6.	--no setting--		
7.	--no setting--		
8.	--no setting--		
9.	--no setting--		
10.	--no setting--		
11.	--no setting--		
12.	--no setting--		
13.	--no setting--		
14.	--no setting--		
15.	--no setting--		

1. On the **Tour** screen, click **Edit** to open the Tour Set options.
2. Select the number of the new tour from the **Tour Line** list at the top of the screen.
3. Select each Preset to add to the tour.
4. Enter the Dwell Time (0~127 seconds) and Speed (0~14) for each Preset.
5. Click **Save** when finished.

## Tour Run

Select the desired tour from the list under **Tour Run** and click **Go**.

To view the camera in full screen mode, move the cursor onto the live view pane, right-click and select **Fullscreen**.

To stop running the Tour, move the cursor to the live view pane and use the PTZ controls to move the camera in any direction.

# Home

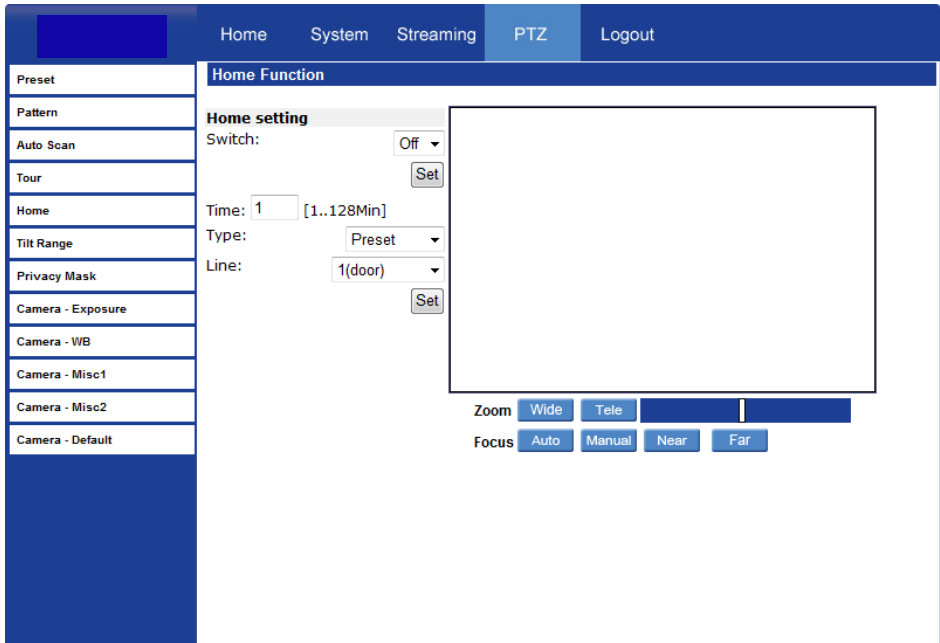

Set up the Home function to ensure constant monitoring. If the camera idles for a period of time, the selected function will be activated automatically and return the camera to the home function setting. The Home function allows constant and accurate monitoring to prevent the camera from idling or missing events.

## Home Settings

### Activate/Disable Home Function

Select ON/OFF to activate or disable the Home function and click **Set** to save.

### Time

Specify the desired idle time (1~128 minutes) in the Time box. The **Time** represents the duration of time the camera can idle before performing the home function. When the Home function is activated, the camera will start to count down when it idles, and then execute the predefined action when time expires.

### Action Type

Select an action **Type** (Preset, Pattern, Auto Scan, or Tour) and then specify the desired action type number from the **Line** list. Click **Set** to save your settings.

## Tilt Range

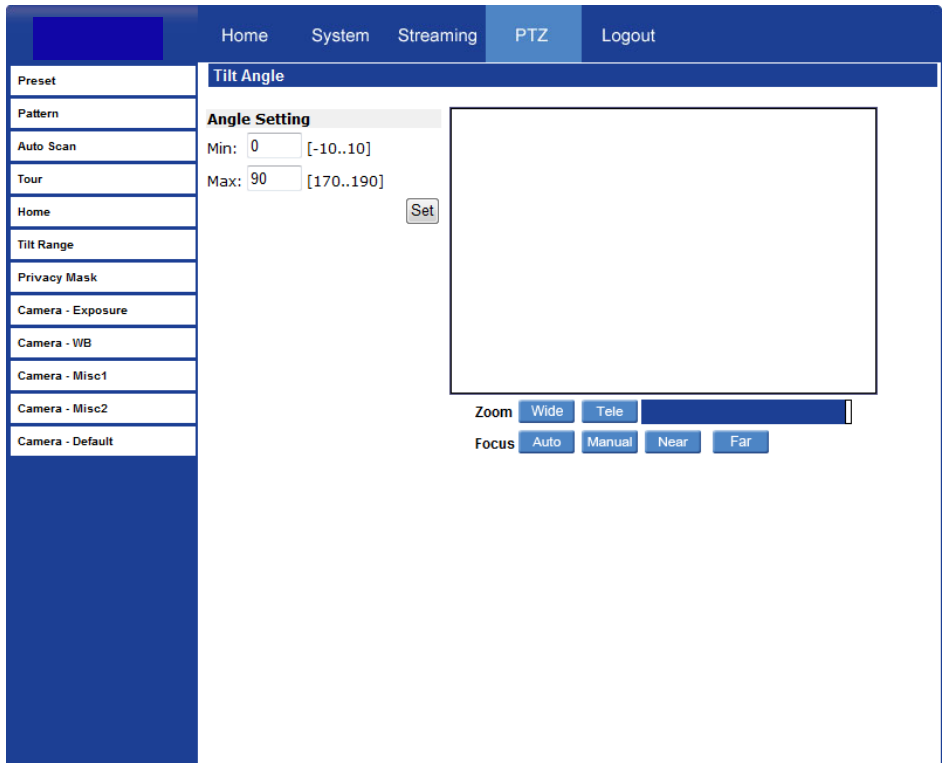

The camera's Tilt Range is adjustable. The minimum tilt angle can be set between -10° and 10°. The maximum tilt angle can be set between 170° and 190°.

- Enter the desired min. and max. tilt angle into the corresponding fields respectively and click **Set** to save the tilt angle settings.

# Privacy Mask Settings

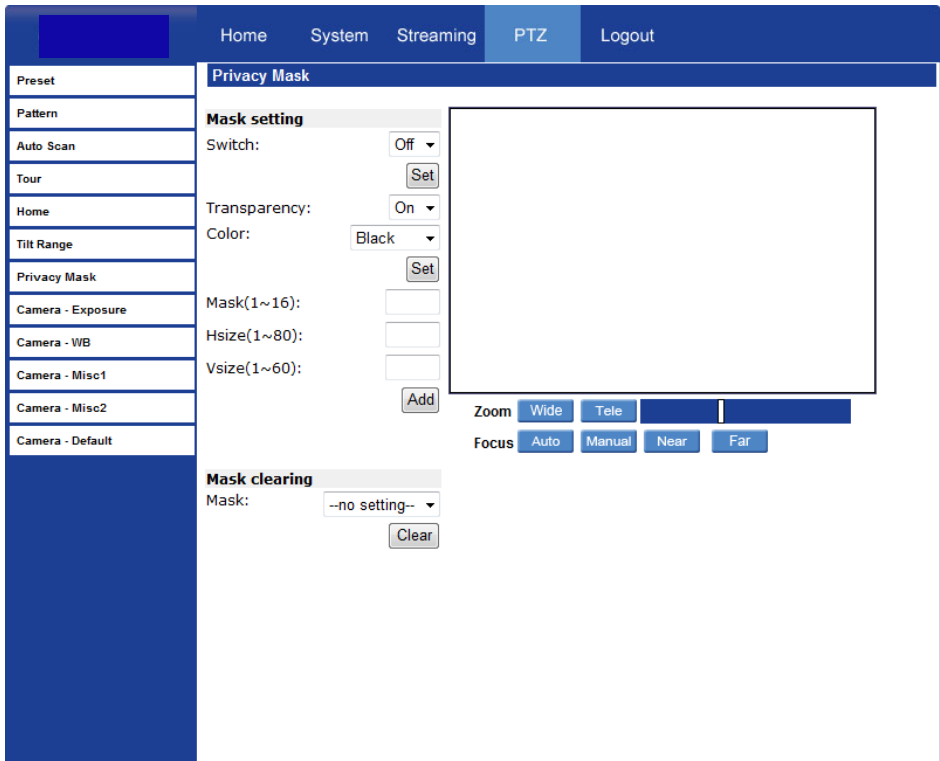

The Privacy Mask function helps avoid any intrusive monitoring. When you create a mask, Toshiba recommends that you set it at least twice as big (height and width) as the masked object. The camera will assume the center of the selected view as a starting point. Therefore, keep the target object/region nearly positioned in the center of the scene.

**Note** The Image Flip function (*PTZ > Camera – Misc1*) will be disabled automatically when the Privacy Mask function is enabled.

## ***Mask Setting***

### **Activate/Disable Privacy Mask Function**

Set to On/Off to activate or disable the Privacy Mask function and click **Set**.

### **Activate/Disable Transparency Mask**

Set the transparency of the Privacy Mask if necessary.

### **Color Setting**

Select the desired color from the **Color** list for the specified Privacy Mask and click **Set**.

### **Mask Number**

Specify the number of the programmed Privacy Mask in the corresponding field.

### **Mask Size**

Specify the horizontal (Hsize: 1~80) and vertical (Vsize: 1~60) size of the Privacy Mask.

Click **Add** to save the programmed Privacy Mask.

## ***Mask Clearing***

To delete an existing Privacy Mask select the Privacy Mask to be removed from the **Mask** list under **Mask Clearing** and click **Clear**.

# Camera — Exposure

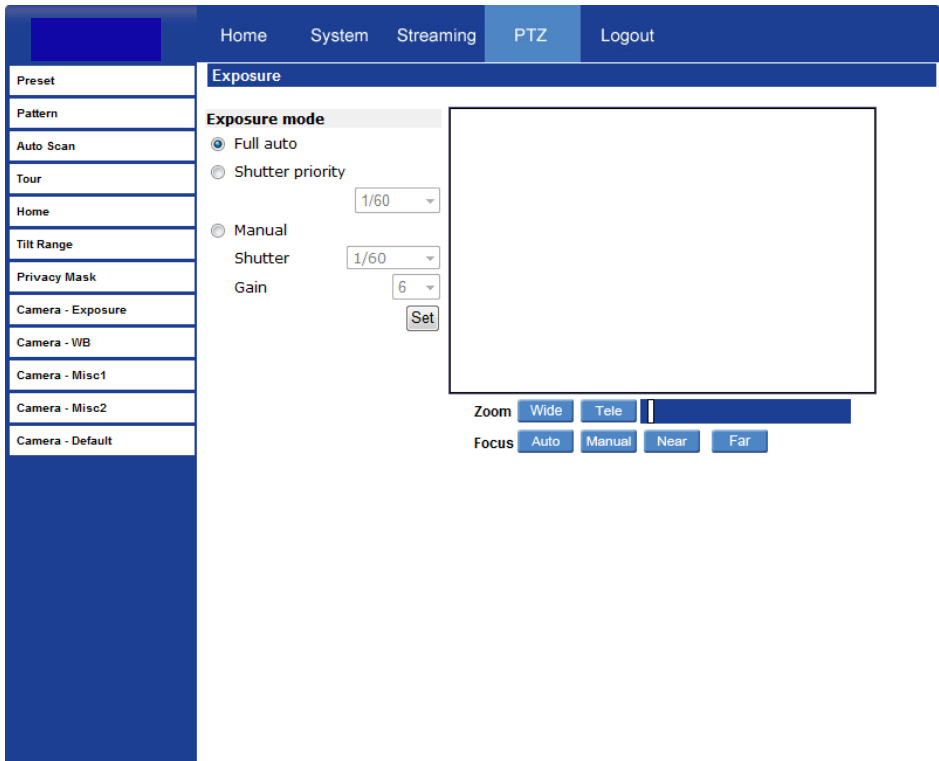

On the Exposure screen you can select **Full Auto** mode or adjust the parameters manually for optimized video output in accordance with the operating environment.

## **Shutter Priority**

When **Shutter Priority** is selected the shutter speed takes control of exposure. Shutter speed range is 1/60 ~ 1/10000.

## **Manual Mode**

Select **Manual** mode to adjust the **Shutter** speed and **Gain** manually. When manual is selected the Shutter speed range is 1 ~ 1/10000; and Gain range is 1 ~ 15.

# Camera — White Balance

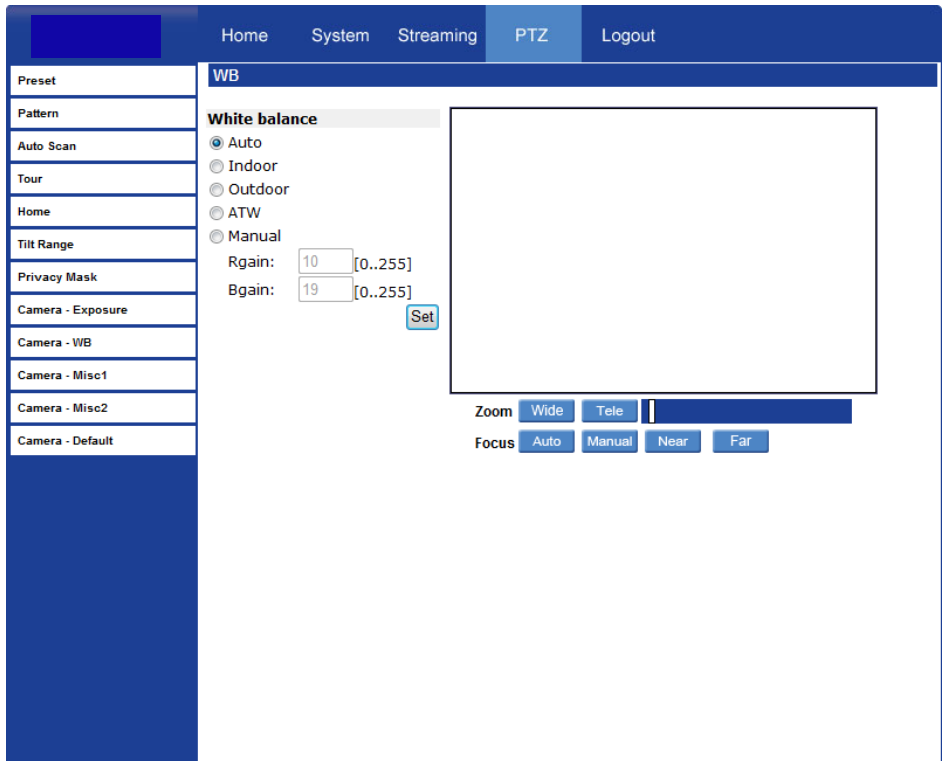

A camera uses a reference color temperature, which is a way of measuring the quality of a light source, to calculate all the other colors. The unit for measuring this ratio is degrees Kelvin (K). You can select the White Balance Control according to the operating environment. The following table shows the color temperature of some light sources for reference.

Light Sources	Color Temperature in K
Cloudy Sky	6,000 to 8,000
Noon Sun and Clear Sky	6,500
Household Lighting	2,500 to 3,000
75-watt Bulb	2,820
Candle Flame	1,200 to 1,500

### **Auto Mode**

In Auto mode, white balance works within its color temperature range and calculates the best-fit white balance.

### **Indoor/outdoor Mode**

Select for indoor or outdoor mode.

### **ATW Mode (Auto Tracing White Balance)**

The Dome Camera takes out the signals in a screen in the range from 2000 K to 10000 K.

### **Manual Mode**

In Manual mode, you can change the White Balance value manually by a specifying the R gain and B gain; the R/B gain range is from 0 to 255.

## Camera — Misc1

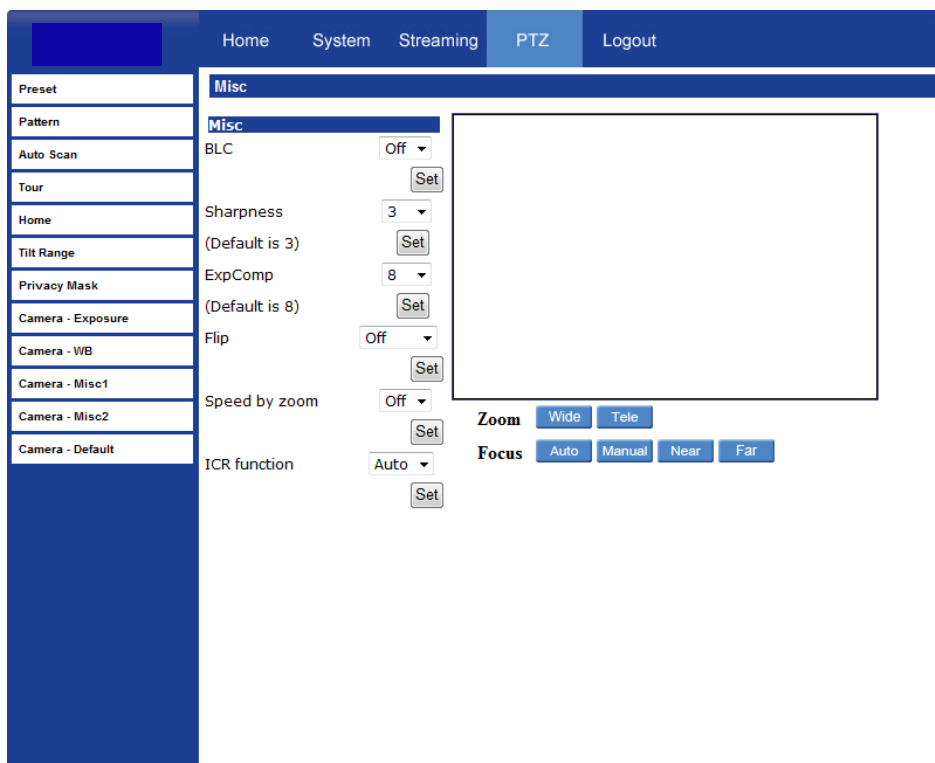

In Camera—Misc1, you can set various camera parameters including Backlight Compensation, Sharpness, Exposures Compensation, Image Freeze, Image Flip, Digital Zoom, Speed by Zoom and ICR Function.

- **BLC** – Activate or disable the Backlight Compensation function (On/Off).
- **Sharpness** – Increasing the sharpness level (1~15) can make the image looked sharper; especially enhancing the object's edge.
- **ExpComp** – Define the value of Exposure Compensation (1~15).
- **Freeze** – Freeze function allows you to hold the image while the camera is moving between preset positions such as in Preset mode and Tour mode (On/Off).

- **Flip** – Track an object continuously when it passes under the camera by setting Flip to Mechanical (M.E.) mode or Digital Flip (Image) mode.
- **M.E. Mode** – M.E. is a standard mechanical operation. As the camera tilts to the maximum angle, it will pan 180°, and then continue tilting to keep tracking objects.
- **Image Mode** – Image represents digital IMAGE FLIP, which enables the camera to keep tracking objects seamlessly. With the Image mode, almost no delay occurs in comparison to the M.E. mode.

**Note** Flip setting is manual-controlled only. If a Preset Position or a point for other function (ex. Tour) is set in the position that can only be reached through FLIP motion, the Flip function must be enabled for the camera to move to that position.

**Note** To make the Dome Camera tilt between a specific range, such as -10° or +190°, please go to the **Tilt Range** setting page to set the tilt angle range. Otherwise, the Dome Camera will tilt 90° as the default setting.

**Note** The Privacy Mask function will be automatically disabled if the Image Flip function is enabled.

- **Speed by Zoom** – Enable this function to have the pan and tilt speed (angle distance) automatically scaled down when the camera is zoomed in. Enabling this function will cause pan and tilt movements to be done in smaller increments the further in the camera is zoomed, making movement while zoomed much easier.
- **ICR Function** – The camera uses the IR cut filter to capture a clear image at night time or in low light conditions. In the Auto mode, the internal circuit will automatically decide when to remove the IR cut filter according to the image brightness level.

## Camera — Misc2

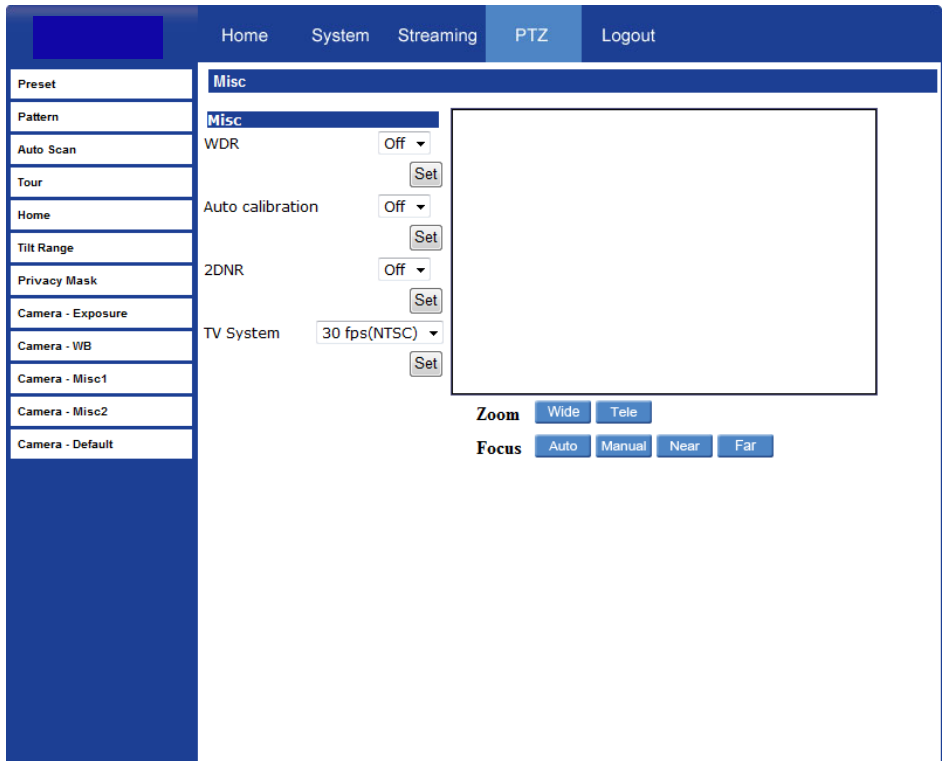

In Camera—Misc2, you can set up various functions such as Auto Calibration, Wide Dynamic Range, 2D Noise Reduction and TV System.

- **WDR** – Wide Dynamic Range is especially effective in an environment with extreme contrast.
- **Auto Calibration** – Auto Calibration function automatically calibrates the camera when the deviation of dome pivot is detected.
- **2DNR** – 2D Noise Reduction function analyzes pixel by pixel and frame by frame to eliminate environmental noise signal so that the highest quality image can be produced even in low light conditions.

## Camera — Default

Click **Set Default** to reset the camera back to factory default settings.

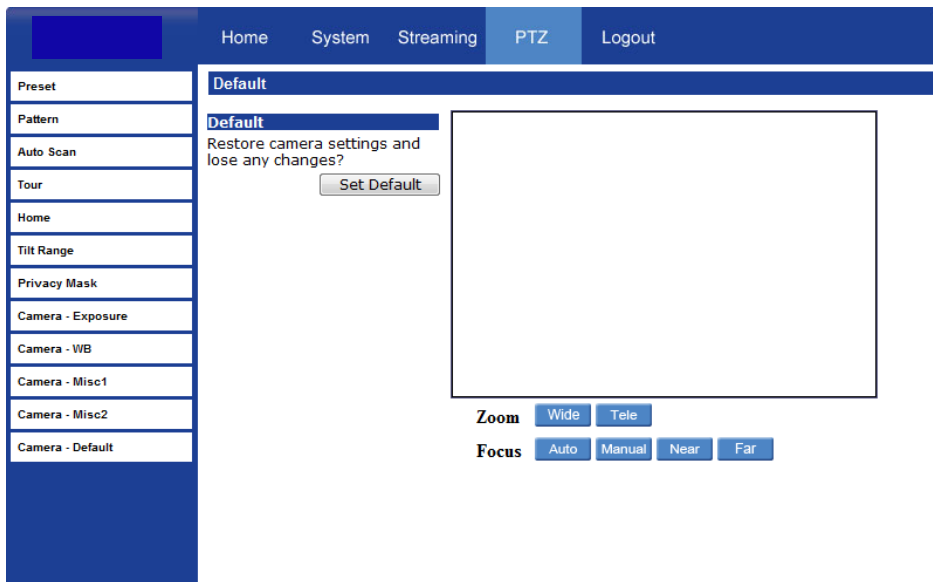

## LOGOUT

---

Click the Logout tab to open the login window and log in with a different user name and password.



# SPECIFICATIONS

## CAMERA SPECIFICATIONS

---

<b>Model</b>	<b>IKS-WP816R</b>
<b>Image Sensor</b>	1/2.8" Sony Progressive CMOS
<b>IP Rating</b>	IP66
<b>Type / Format</b>	H.264 / MJPEG
<b>Wide Dynamic Range</b>	Yes
<b>Minimum Illumination</b>	0.1 Lux (Color) / 0.03 Lux (B&W) (@ 50IRE)
<b>Day / Night</b>	Yes (True Day / Night)
<b>Resolution</b>	1080P [1920 x 1080 / 2MP], 1280 x 1024 / 1/3MP, 720P [1280 x 720 / 1MP], 1024 x 768, 800 x 600, 720 x 480, 640 x 480, 352 x 240
<b>Focal Length</b>	4.7 ~ 84.6 mm
<b>Iris Control</b>	Auto / Manual
<b>White Balance</b>	Auto / Indoor / Outdoor / ATW
<b>Auto White Balance Range</b>	2700 K – 10,500 K
<b>Backlight Compensation</b>	On / Off
<b>Auto Gain Control</b>	Auto / Manual
<b>Operating Temperature</b>	-40°F ~ 122°F (-40°C ~ 50°C)
<b>Heater</b>	Yes
<b>Power Consumption</b>	65W (Max, with heater)
<b>Rated Amperage</b>	2.7A
<b>Input Voltage</b>	24vAC±10%
<b>Weight</b>	5.1 lbs (2.32 kg)
<b>Dimensions</b>	<b>Dome:</b> Ø7.5" (191 mm) x <b>H:</b> 11.1" (282 mm)
<b>Housing / Dome Cover</b>	White / Clear

## PTZ SPECIFICATIONS

---

<b>Optical Zoom</b>	18x
<b>Pan/Tilt Range</b>	360° Endless / -10° ~ 190°
<b>Presets</b>	256
<b>Preset Accuracy</b>	± 0.225°
<b>Preset Speed</b>	5° ~ 400°/sec.
<b>Pattern</b>	8
<b>Tour (Group)</b>	8
<b>Auto Scan</b>	4
<b>Privacy Mask</b>	16
<b>Zone Title</b>	16
<b>Home Function</b>	Preset, Pattern, Tour, Autoscan
<b>Auto Flip</b>	Image / Mechanical / Off
<b>Digital Slow Shutter</b>	On / Off
<b>Focus Mode</b>	Auto / Manual
<b>Control</b>	All PTZ functions available through web UI, no OSD
<b>Built-in Protocol</b>	PTZ control via network only

## IP SPECIFICATIONS

---

<b>Dual Streaming</b>	H.264 (Main) + MJPEG / H.264 + H.264
<b>Max IPS</b>	30 IPS @ 1080p
<b>Audio In</b>	1
<b>Audio Out</b>	1
<b>Alarm Inputs</b>	4
<b>Relay Outputs</b>	2
<b>User Accounts</b>	20

[www.toshibasecurity.com](http://www.toshibasecurity.com)

1-877-855-1349

© 2013 Toshiba

All rights reserved. No part of this publication may be reproduced by any means without written permission from Toshiba. The information in this publication is believed to be accurate in all respects. However, Toshiba cannot assume responsibility for any consequences resulting from the use thereof. The information contained herein is subject to change without notice. Revisions or new editions to this publication may be issued to incorporate such changes.