



Made for Toshiba

TECHNICAL SPECIFICATIONS

FB-3010-HB

Environmental Housing with Heater & Blower

A new unique design coming with built-in sun-shield

This weatherproof, dustproof, rustproof housing not only looks good, it also saves mounting time. Made of lightweight extruded aluminum, it can be rapidly installed by only one technician. The front cover, featuring a built-in sun-shield and locked by 2 zinc plated clips and a screw, opens by sliding forward allowing complete camera access. You can even suspend the cover to the mount to free your hands during service. The housing comes with a 24 VAC thermostatic blower & a 24 VAC thermostatic heater. Two medium-duty but super light aluminum mounting brackets are available: **FSM3009** for walls and **FSP3009** for ceilings. To make this enclosure tamperproof, replace the Phillips screw with our security "Hex" screw.

Fabrication :

Body : All aluminum, 11 ga. , #3003-H14 & #6063-T5 alloys
 Window : 3/16" clear polycarbonate, abrasive resistant
 Cover : Removable, sealed, locked by 2 zinc plated clips and a screw
 Finish : White polyurethane coating
 Weight : 4.0 lb (1.9 kg)

Internal Dimensions:

Height: 3.0" (76 mm)
 Width: 4.0" (102 mm)
 Length: 11.5" (294 mm)

External Dimensions:

Height : 4.875" (125 mm)
 Width : 6.0" (152 mm)
 Length: 14.625" (374 mm)
 Camera : 10.0" (254 mm) Max. Length

Products	Intensity	Temperature range
FB-3010HB:	9.5 Watts	-5°C to +49°C (23°F to 120°F)

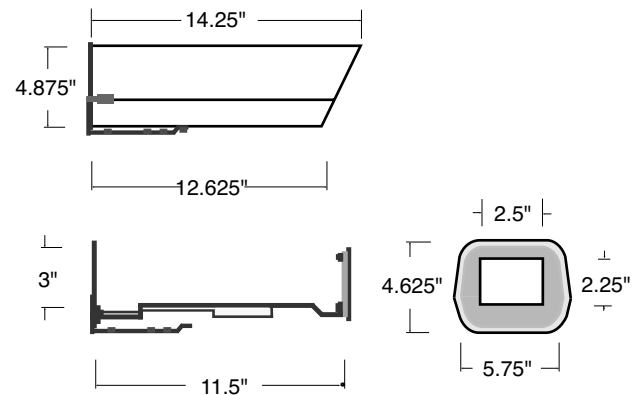

Accessories

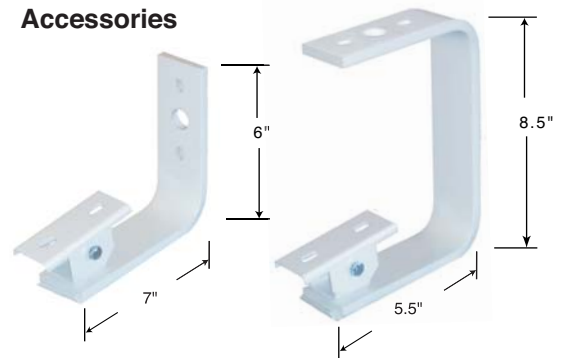

FSM3009
Wall mount

FSP3009
Ceiling mount

Inches